

Properties

The standard range of ceramic infrared elements in stock are used in a wide range of industrial and engineering applications such as thermoforming, packaging, paint curing, printing, drying, gluing, sterilisation, roasting etc. They are also very effectively used in infrared outdoor heaters and saunas.

Most plastics and many other materials absorb infrared best in the wavelength range of 2-10 μm , which makes the ceramic heater the most popular radiant emitter on the market.

Technical specification

Material	Ceramic solid body in white glaze colour with an embedded resistance heating coil
Heater Voltage	230 V (standard)
Operating Temperature	Max permissible 750°C
Useful wave-length range	2 - 10 μm (microns) long wavelength
Dimensions	122 x 122 x 37.5 mm
Average weight	284 g
Electric connection	120 mm ceramic beaded power leads
Assembly	Recommended radiation distance from heater is 100mm to 200mm. Mounting slot size oval 15x42 mm Steel wave spring and clip set included
Recommended Spacing	5mm minimum spacing between elements
Average operating life	Up to 20 000 hrs depending on conditions
Standards	CE
Packaging w x h x d	126 x 126 x 50 mm



Standard assortment

Model SFEH	Power W	Mean Surface Temperature °C	Max Power Density kW/m ²
SFEH 250	250	390	15
SFEH 400	400	497	24
SFEH 500	500	548	30
SFEH 600	600	602	36
SFEH 800	800	710	48

SFEH - Square Flat Element Hollow

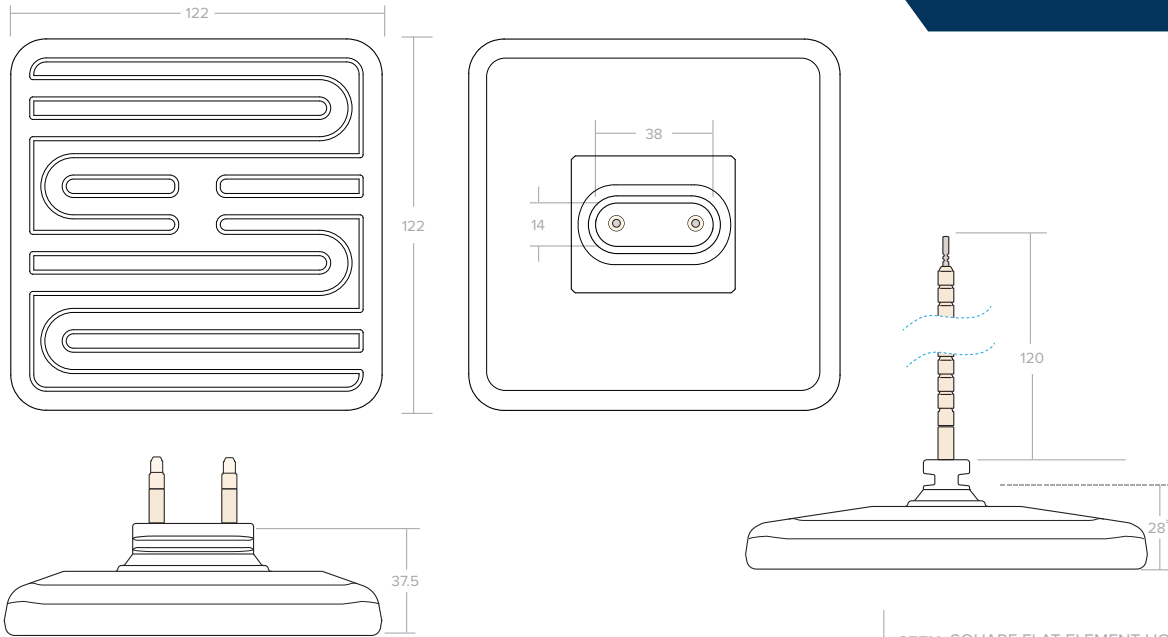

SFEH SQUARE FLAT ELEMENT HOLLOW

Tolerances apply, all dimensions mm.
 * Face of reflector - face of element using 0.75mm reflector, mounting hole size 15 x 42 mm

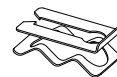

Comes with Wave Spring and Clip

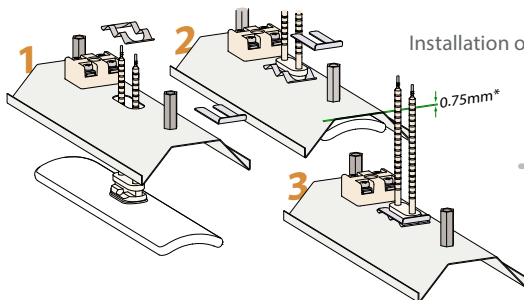

Installation of pillared elements

Recommended reflector thickness
 0.75 - 0.9 mm
 0.0296" x 0.0354"
 min/max thickness 0.5 - 1.5 mm
 0.0197" x 0.059"

Recommended Slot hole
 size 42 x 15 mm

1.6535" x 0.5905"

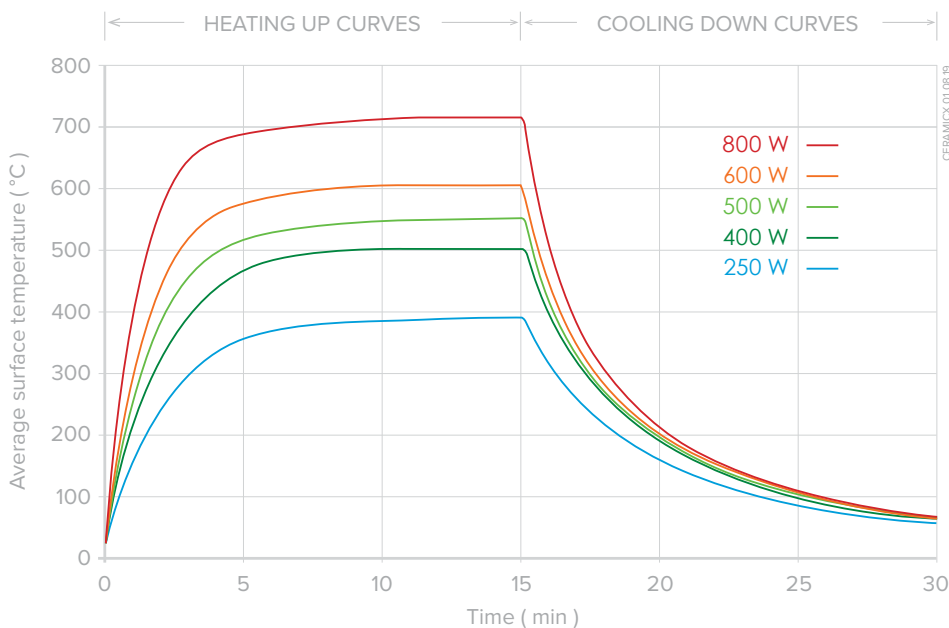

SFEH Square Flat Element Hollow

Heating up and cooling down curves showing average surface temperature taken with an infrared thermometer set at an emissivity of 0.95 (Element mounted in an aluminised steel reflector RAS)