

5 DIGITAL MICRO-PROCESS SIGNAL ISOLATED TRANSMITTER

ATM-A

FEATURES

- Accuracy: $\pm 0.1\%$ F.S. (DC / Potentiometer / Resistor / PT-100 / Load Cell)
 $\pm 0.2\%$ F.S. (AC)
- Measuring AC, DC Voltage / AC, DC Current / Potentiometer / Resistor / PT-100 / Load Cell)
- High brightness 0.4" LED display range: -19999~99999; decimal point selectable
- Surge test of AC 2000V / min between input / output / power
- High stability, non-flammable case (PC), high safety



ORDER INFORMATION: ATM-A- [Code 1] [Code 2] - [Code 3] - [Code 4]

Code 1	Input Type	Code 2	Voltage	Code 2	Current	Code 2	Potentiometer	Code 2	Resistor	Code 2	RTD (PT-100)	Code 2	Load Cell	Code 3	Aux. Power	Code 4	Analog Output
D	DC	V1	0~50mV	A1	0~20uA	P1	500Ω~10KΩ	I1	0~10Ω	T1	-50~50℃	L1	1mV/V EX.5V	A	AC/DC 100~240V	1	4~20mA
A	AC AVG	V2	0~5V	A2	0~200uA	P2	10KΩ~100KΩ	I2	0~100Ω	T2	0~50℃	L2	2mV/V EX.5V	D	AC/DC 22~60V	2	0~20mA
M	AC TRMS	V3	1~5V	A3	0~2mA	P3	100KΩ~1MΩ	I3	0~1KΩ	T3	0~100℃	L3	3mV/V EX.5V	O	Option	3	0~5V
P	3 Wire Potentiometer	V4	0~10V	A4	0~20mA	PO	Option	I4	0~10KΩ	T4	0~200℃	L4	1mV/V EX.10V			4	0~10V
I	2 Wire Resistor	V5	0~36V	A5	0~200mA			I5	0~100KΩ	T5	0~400℃	L5	2mV/V EX.10V			L	LoopPower: 15~30 Vdc 4~20 mA
T	RTD (PT-100)	V6	0~300V	A6	4~20mA			IO	Option	T6	0~600℃	L6	3mV/V EX.10V			O	Option
L	Load Cell	V7	0~600V	AO	Option					TO	Option	LO	Option				
2	2, 3 Wire Sensor	VO	Option														
4	4 Wire Sensor																

**1: 2 wire type offers excitation power DC24V for 2 wire (Loop Power) pressure, temperature, humidity sensors using.
2: 3.4 wire type offers excitation power DC24V for 3, 4 wire (Loop Power) pressure, temperature, humidity sensors using.

SPECIFICATION

- ◆ Accuracy: $\pm 0.1\%$ F.S. (DC / Potentiometer / Resistor / PT-100 / Load Cell)
 $\pm 0.2\%$ F.S. (AC)
- ◆ Display Screen: High brightness red LED; 10.16mm (0.4")
- ◆ Display Range: -19999~99999
- ◆ Zero Adjustment: ± 9999
- ◆ Span Adjustment: ± 9999
- ◆ Over Range Indication: doFL / ioFL or -doFL / -ioFL
- ◆ Polarity Indication: Automatic with "-" indication
- ◆ Parameters Setting: Push buttons
- ◆ Back Up Memory: EEPROM
- ◆ Analog Output Resolution: 15 bit
- ◆ Output Response Time: <250 msec (0~90%)
- ◆ Output Capability: Voltage Output: <20mA
Current Output: <10V
- ◆ Output Ripple: $\leq \pm 0.1\%$ F.S.
- ◆ Isolation: Input / Output / Power / Case
- ◆ Temperature Coefficient: 100ppm / °C (0~60℃)
- ◆ Operating Temperature: 0~60℃
- ◆ Operating Humidity: 20~90% RH (non-condensing)
- ◆ Storage Temperature: -10~70℃
- ◆ Storage Humidity: 20~90% RH (non-condensing)
- ◆ Power Supply: AC/DC 100~240V; AC/DC 22~60V
- ◆ Surge Test: 2KVac / 1min
- ◆ Insulation Resistance: >100MΩ with 500Vdc
- ◆ Input Impedence: Voltage: >2V for 20KΩ / V; $\leq 2V$ for >200MΩ
Current: $\geq 0.2A$ at 100mV; <0.2A at 1V
- ◆ Installation: Socket / Plug in

FRONT PANEL & KEY FUNCTIONS

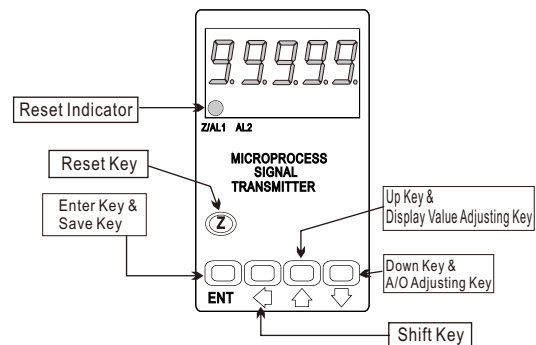

DIMENSION

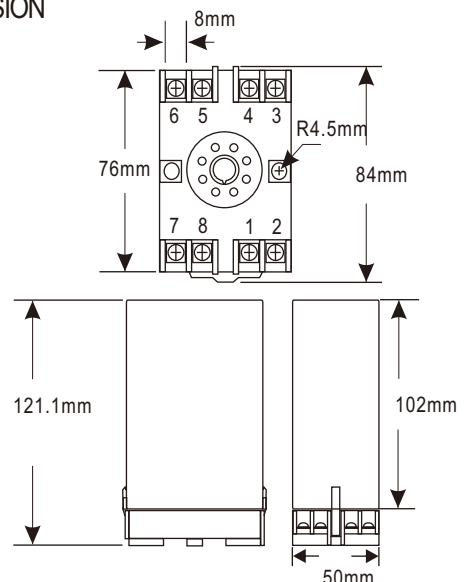

■ WIRING CONNECTION

- Voltage, Current (AC, DC)

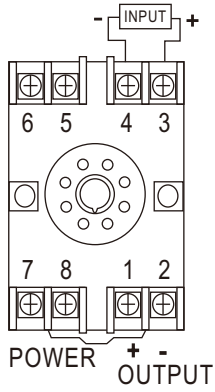

- 4 Wire Sensor or Load cell

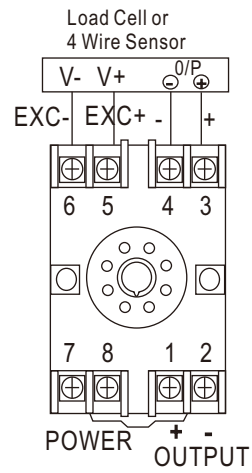

- Temperature (RTD)

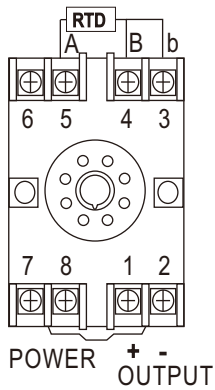

- 2 Wire Sensor

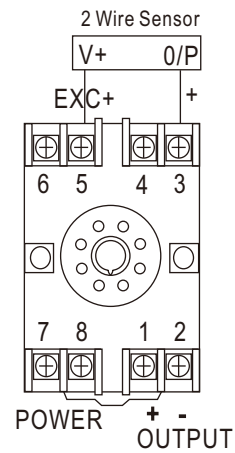

- 2 Wire Resistor

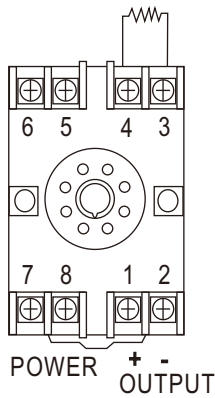

- 3 Wire Sensor

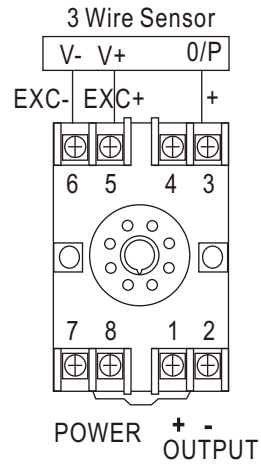

- 3 Wire Potentiometer

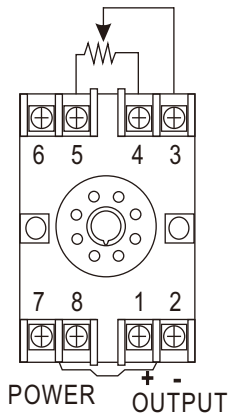

* Please understand key indicators & functions at the first operation.

FRONT PANEL & KEY FUNCTIONS

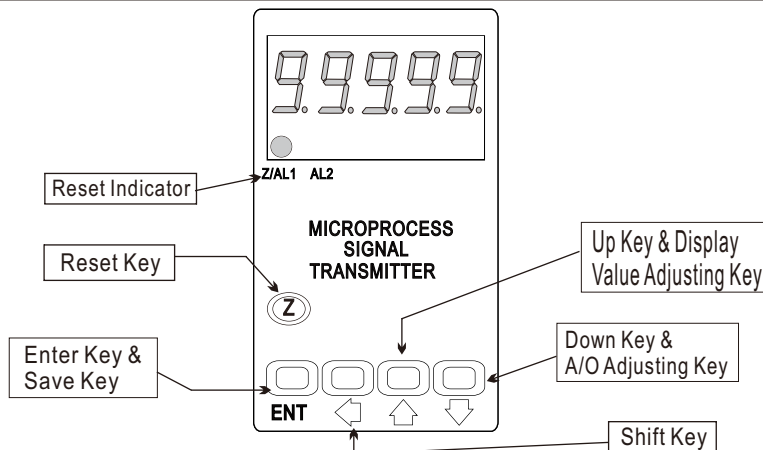

Key Name	Symbol	Descriptions
Reset Key		1. Press this key to enable the reset function & reset indicator (Z) is light; press this key again to disable the reset function & reset indicator (Z) is dark.
Enter Key & Save Key	ENT	1. In the measuring status, press this key can enter to parameter pages. 2. In the parameter setting, press this key can save the value & go to next page.
Shift Key		1. In the parameter setting, press this key can move the cursor left.
Up Key & Display Value Adjusting Key		1. In the measuring status, press this key for 3 sec can enter to display adjustment of "ZERO" & "SPAN" 2. In the parameter setting, press this key can increase the digits.
Down Key & A/O Adjusting Key		1. In the measuring status, press this key for 3 sec can enter to analog output adjustment. 2. In the parameter setting, press this key can decrease the digits.

- **1. The following block charts are parameters codes, parameter codes & parameters will alternate flashing if the parameters can be modified.
- 2. To modify the parameters, please press , and press ENT to save the parameters after the modification.
- 3. Please don't forget the new pass code after modification.
- 4. In any pages, press & , or don't press any keys for 2 minutes that will back to measuring status.

GENERAL MODE OPERATING PROCEDURES

Block Charts	Display	Descriptions	Default
Power On		Display: "ZERO" & "SPAN" Adjustment	
	Measuring Status	Present value for measurement.	
	Display (dZEro) Adjustment (dZEro)	Press to select adjusting speed rate, press to modify the zero value. PS: To use this function to adjust the real zero value.	00000
	Display Span Adjustment (dSPAN)	Press to select adjusting speed rate, press to modify the span value. PS: To use this function to adjust the real span value.	00000
		Analog Output: "ZERO" & "SPAN" Adjustment	
	Measuring Status	Present value for measurement.	
	A/O Zero Adjustment (AZEro)	Press to select adjusting speed rate, press to modify the A/O zero. PS: To use this function to adjust the real A/O zero.	00000
	A/O Span Adjustment (ASPAn)	Press to select adjusting speed rate, press to modify the A/O span. PS: To use this function to adjust the real A/O span.	00000

PROGRAMMING MODE OPERATING PROCEDURES

Block Charts	Display	Descriptions	Default
	Measuring Status	Present value for measurement.	
	Pass Code (P.Cod)	Press \leftarrow \uparrow \rightarrow to enter pass code.	00000
		Pass code is correct that will enter to parameter groups. Pass code is wrong that will back to measuring status.	
	Decimal Point Setting (dP)	Press \uparrow \rightarrow to select decimal point (0, 1, 2, 3, 4). EX: if the value shows "0.00" that means the decimal point is 2 digits.	
	Display Low Scale Setting (dSPL)	Press \leftarrow \uparrow \rightarrow to modify display low scale for the input signal zero value. EX: If the input signal is 4~20mA; 4mA is shown display 0.00, this parameter must be set for 000.00.	Customers specify
	Display Hi Scale Setting (dSPH)	Press \leftarrow \uparrow \rightarrow to modify display high scale for the input signal span value. EX: If the input signal is 4~20mA; 20mA is shown display 100.00, this parameter must be set for 100.00.	Customers specify
	Display Average Setting (Avg)	Press \leftarrow \uparrow \rightarrow to modify display average (1~99). PS: Please use this function for stable display value when input signal is unstable.	00005
	Display Low Cut Setting (LCut)	Press \leftarrow \uparrow \rightarrow to modify display low cut to 0 (0~99).	00000
	A/O Polarity Setting (PoLAR)	Press \leftarrow \uparrow \rightarrow to modify output is positive pole or negative pole. PS: Voltage output, NO: positive pole output (0~+10V) YES: positive & negative pole output (-10~+10V)	no
	A/O Low Scale Setting (AnLo)	Press \leftarrow \uparrow \rightarrow to adjust A/O low scale to correspond to the display value. EX: A/O is 0~10V, the display is 10.0 to output 0V, this value must be set for 10.0.	00000
	A/O Hi Scale Setting (AnHi)	Press \leftarrow \uparrow \rightarrow to adjust A/O hi scale to correspond to the display value. EX: A/O is 0~10V, the display is 90.0 to output 10V, this value must be set for 90.0.	99999
	Pass Code Setting (CodE)	Press \leftarrow \uparrow \rightarrow to modify pass code (0~19999). PS: Please don't forget the new pass code after modification.	00000
	Key Lock Setting (LoCK)	Press \uparrow \rightarrow to lock the keys, using key lock function only can view the parameters, but cannot modify any values. PS: no (unlock), YES ("ENT" unlock, others lock).	no

Error Code of Self-Diagnosis

Display	Descriptions	Display	Descriptions
1, oFL	Input signal is over 120% of input range.	doFL	Input signal is over display range (99999).
-1, oFL	Input signal is under -20% of input range.	-doFL	Input signal is under display range (-19999).
AdEr	Input signal is over 180% of input range or meter error.	E-00	EEPROM reading/writing suffers the interference (about 1 million times).

**Please check the wiring connection is correct first, if the problem still exist, please return the meter to the factory.

CALIBRATION OPERATING PROCEDURES

Block Charts	Display	Descriptions	Default
	Measuring Status	Present value for measurement Press ENT & \leftarrow together for 3 sec will enter to calibration operating procedures.	
	Input Low Scale Calibration (inLo)	1. Input standard low scale signal. 2. Press \leftarrow \uparrow \rightarrow to calibrate input low scale.	
	Input Hi Scale Calibration (inHi)	1. Input standard hi scale signal. 2. Press \leftarrow \uparrow \rightarrow to calibrate input hi scale.	
	System Setting Page (SYS)	1. Finish calibration operating procedures will enter to system setting group. 2. Press \uparrow & \rightarrow together to back to measuring status.	

Warning: Calibration of this meter requires a standard signal with 0.01% accuracy or better and an external meter with 0.005% accuracy or better.