

# DUAL OUTPUT SIGNAL ISOLATED TRANSMITTER

# ATD

## FEATURES

- Accuracy:  $\pm 0.1\%$  F.S. (DC / Potentiometer / Resistor / PT-100 / Load Cell)  
 $\pm 0.2\%$  F.S. (AC)
- Measuring AC, DC Voltage / AC, DC Current / Potentiometer / Resistor / PT-100 / Load Cell)
- Surge test of AC 2000V / min between input / output / power
- High stability, non-flammable case (PC), high safety



## ORDER INFORMATION : ATD - [Code 1] [Code 2] - [Code 3] - [Code 4] [Code 5]

Code 1	Input Type	Code 2	Voltage	Code 2	Current	Code 2	Potentiometer	Code 2	Resistor	Code 2	RTD (PT-100)	Code 2	Load Cell	Code 3	Aux. Power	Code 4	Analog Output 1	Code 4	Analog Output 2
D	DC	V1	0~50mV	A1	0~20uA	P1	500Ω~10KΩ	I1	0~10Ω	T1	-50~50℃	L1	1mV/V EX.5V	A	AC/DC 100~240V	1	4~20mA	1	4~20mA
A	AC AVG	V2	0~5V	A2	0~200uA	P2	10KΩ~100KΩ	I2	0~100Ω	T2	0~50℃	L2	2mV/V EX.5V	D	AC/DC 22~60V	2	0~20mA	2	0~20mA
M	AC TRMS	V3	1~5V	A3	0~2mA	P3	100KΩ~1MΩ	I3	0~1KΩ	T3	0~100℃	L3	3mV/V EX.5V			3	0~5V	3	0~5V
P	3 Wire Potentiometer	V4	0~10V	A4	0~20mA	PO	Option	I4	0~10KΩ	T4	0~200℃	L4	1mV/V EX.10V			4	0~10V	4	0~10V
I	2 Wire Resistor	V5	0~36V	A5	0~200mA			I5	0~100KΩ	T5	0~400℃	L5	2mV/V EX.10V			0	Option	0	Option
T	RTD (PT-100)	V6	0~300V	A6	4~20mA			I0	Option	T6	0~600℃	L6	3mV/V EX.10V						
L	Load Cell	V7	0~600V	A0	Option					T0	Option	L0	Option						
2	2, 3 Wire Sensor	V0	Option																
4	4 Wire Sensor																		

- \*\*1: 2 wire type offers excitation power DC24V for 2 wire (Loop Power) pressure, temperature, humidity sensors using.  
 2: 3.4 wire type offers excitation power DC24V for 3, 4 wire (Loop Power) pressure, temperature, humidity sensors using.  
 3: Load Cell type of excitation power DC5V can have 2 load cell in parallel; DC10V only can offer 1 load cell to use.

## SPECIFICATION

- ◆ Accuracy:  $\pm 0.1\%$  F.S. (DC / Potentiometer / Resistor / PT-100 / Load Cell)  
 $\pm 0.2\%$  F.S. (AC)
- ◆ Zero Adjustment:  $\leq \pm 5\%$  F.S.
- ◆ Span Adjustment:  $\leq \pm 10\%$  F.S.
- ◆ Output Response Time: <250 msec (0~90%)
- ◆ Output Capability: Voltage Output: <20mA  
Current Output: <10V
- ◆ Output Ripple:  $\leq \pm 0.1\%$  F.S.
- ◆ Isolation: Input / Output / Power / Case
- ◆ Temperature Coefficient: 100ppm / °C (0~60℃)
- ◆ Operating Temperature: 0~60℃
- ◆ Operating Humidity: 20~90% RH (non-condensing)
- ◆ Storage Temperature: -10~70℃
- ◆ Storage Humidity: 20~90% RH (non-condensing)
- ◆ Power Supply: AC/DC 100~240V, AC/DC 22~60V
- ◆ Surge Test: 2KVac / 1min
- ◆ Insulation Resistance: >100MΩ with 500Vdc
- ◆ Input Impedence: Voltage: >2V for 20KΩ / V;  $\leq 2V$  for >200MΩ  
Current:  $\geq 0.2A$  at 100mV; <0.2A at 1V
- ◆ Installation: Socket / Plug in

## CALIBRATION

### Steps:

1. Input the zero value and adjust each ZERO VR to the zero point.
2. Input the span value and adjust each SPAN VR to the span point.

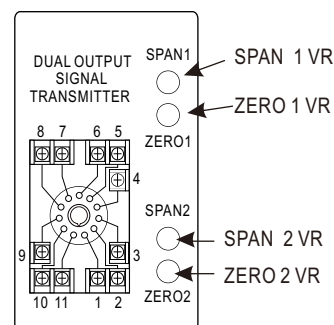

## DIMENSION

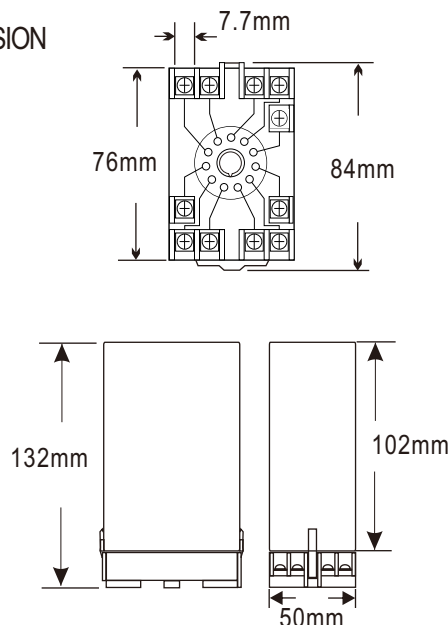

## ■ WIRING CONNECTION

### ● Voltage, Current (AC, DC)

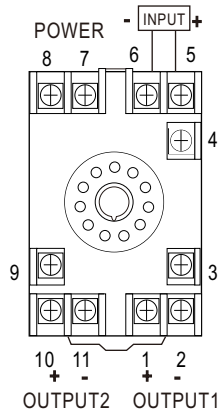

### ● 4 Wire Sensor or Load cell

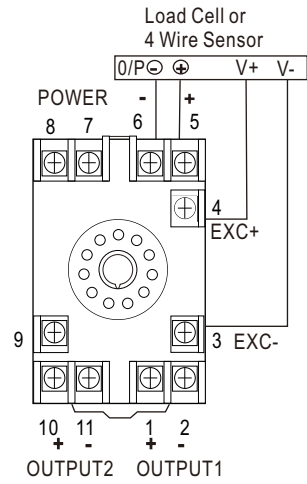

### ● Temperature (RTD)

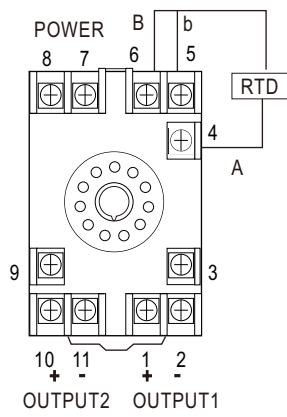

### ● 2 Wire Sensor

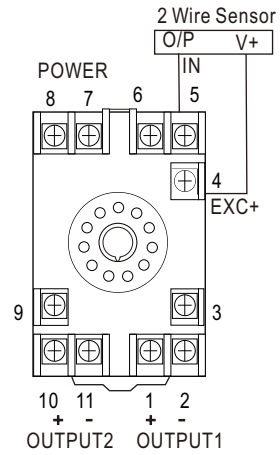

### ● 2 Wire Resistor

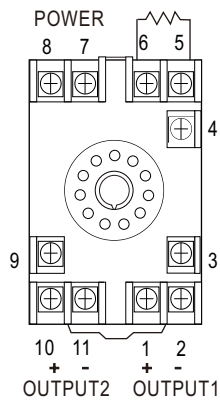

### ● 3 Wire Sensor

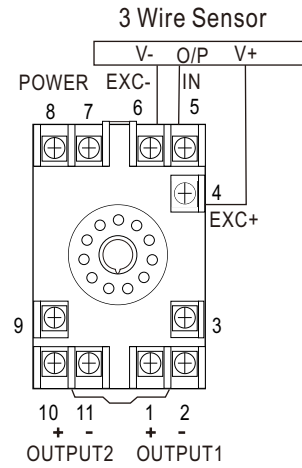

### ● 3 Wire Potentiometer

