

## Differential pressure gauges with diaphragm for the chemical industry New: as pressure gauge multifunctional

with or without liquid filling

with or without electrical alarm contacts

with or without electrical output

Nominal size ND 100 and ND 160



P2680



P2684 / P2694

### Description

Differential pressure gauges are ideal for the hard conditions and the resulting high demands on pressure measurement in production facilities in chemical industry and other comparable branches. The use of high quality materials such as stainless steel makes the measuring system and the case resistant against chemically aggressive media and ambient.

Depending on the application, the gauges can be delivered with filling liquid. The filling liquid provides wear-protection for the measuring system through dampening, should pulsating pressures and mechanical vibrations occur.

Differential pressure gauges with electrical alarm contacts or electrical output are suitable for controlling or regulating process sequences with the aid of the process pressure.

### Function

Principle item of these differential pressure gauges is the pressure chamber with two "hydraulically" connected diaphragms with a liquid bolster between the diaphragms. In case both diaphragms with a liquid bolster between the diaphragms are set under different pressure, the displacement into one direction is transformed by a movement to a proportional pointer deflection.

### Features

- o Measuring chamber and case of corrosion resistant materials, stainless steel
- o Static pressure and overloadable up to 40 bar, optional up to 400 bar
- o Electric alarm contacts or electrical output
- o Flushing connection for the pressure chamber
- o Pressure connection according to DIN 19 213
- o Vibration-free display and long life term stability through liquid damping

### Ranges



0....60 mbar to 0....40 bar

### Applications

Level measurements in pressurised vessels,  
Filter monitoring,  
Flow measurement.

**Models: P2680, P2681, P2683, P2684,  
P2690, P2691, P2693, P2694**

## Technical data

Models	P2680	P2690	P2681	P2691	P2683	P2693	P2684	P2694	Options
Nominal size	100	160	100	160	100	160	100	160	
Design									
Liquid filling	without Option: Glycerine / Water		without				Silicone oil <i>P2680/P2681</i> : Glycerine		
Contact type	without		Magnetic snap action		Inductive		Multifunctional		
Accuracy class	1.6 acc. to EN 837-3								
Ranges	0 ... 60 mbar to 0 ... 250 mbar (Measuring chamber DN 140) 0 ... 0.4 bar to 0 ... 40 bar (Measuring chamber DN 80) negative or positive and negative/positive gauge pressure								
Type	for max. gauge pressure (static pressure) 40 bar						100 / 250 / 400 bar		
Overload protection	⊕ resp. ⊖ side max. 40 bar					high overload protection: max. 0...400 bar		40 / 100 / 250 / 400 bar	
Applications	Constand load: end scale value Alternating load: 0.9 x end of scale value								
Case	Stainless steel, 1.4301, polished							Liquid filling	
Bezel	Stainless steel, 1.4301, bayonet ring							Mounting flange front	
Mounting	displayed by symbols: (+) high pressure, (-) low pressure								
Fixing via	rigid measuring lines, Mounting holes in the flansh							Mounting flange front, surface mounting bracket for wall or pipe mounting	
Window	Laminated safety glass								
Dial	Aluminium, white, scale and lettering, black								
Pointer	Alu. black micro-adjustable pointer		Aluminium, black			Alu. black micro-adjustable pointer			
Zero-point adjustment	micro-adjustable pointer		Adjusting device on case: external at the enclosure at 12 h			micro-adjustable pointer			
Movement	Stainless steel								
Measuring element	≤ 250 mbar stainless steel, 1.4571 ≥ 400 mbar NiCrCo-alloy, Duratherm 600							<i>P2684 / P2694</i> : to < 0.4 bar stainless steel, ≥ 0.4 bar NiCrCo-alloy (Duratherm)	
								Special material	
Sealing	FPM, sealing Viton <sup>®</sup> 3) (medium wetted)							PTFE	
Pressure connection	Stainless steel, 1.4571								
- position	radial, bottom							back	
- thread	2x G 1/2 female thread							Other on request Differential process connection per DIN EN 19 213	
Measuring flange, measuring chamber	Stainless steel, 1.4571, measuring chamber filled with silicon oil							Special filling media e.g. for oxygen	
Venting of measuring chamber	Stainless steel, 1.4571 at ranges ≤ 250 mbar							at ranges ≥ 0.4 bar	
Temperatures									
- Media	Tmin. -20°C, Tmax. 100°C								
- Ambient	Tmin. -25°C, Tmax. 60°C								
Temperature drift	0.6% / 10K if deviation from normal temperature 20°C					0.5% / 10K			
CE-Conformity	ATEX: 94/4								
Pressure equipment directive	97/23/EG								
Protection	IP 54 acc. to EN 60 529 / EC 529							Filled pressure gauges: IP 65 acc. to EN 60529 / EC 529	

3) Viton<sup>®</sup> fluoroelastomer, a product of DuPont Dow Elastomers



Mounting advice: (-) low pressure; (+) high pressure

## Special accessories:

Shut-off valve block (one to five spindle) see data sheet AE1215

Electrical data and switching functions see data sheet DE1231 and DE728

## Technical data

Models	P2680	P2690	P2681	P2691	P2683	P2693	P2684	P2694	Options
Nominal size	100	160	100	160	100	160	100	160	
Design									
Contact type	without		Magnetic snap action		Inductive		Electrical output		
Contact function	without		1 - 3		1 - 3		without		
Electrical output	without		without				4...20 mA 0...20 mA 1) 0...10 V by Ex only 4...20 mA		
Electrical connection	---		Cable connector right hand side 6 screw terminals + PE, cross section of the conducting wire 2.5 mm <sup>2</sup> Screw type conduit fitting M20x1.5, outgoing downwards			L-plug connector, 180 ° rotatable, max. 1.5 mm <sup>2</sup> , wire protector, Cable gland M20 x 1.5, external cable diameter 7-13 mm, incl. strain relief		2) plug connector	
Power supply - Supply voltage effect - Permissible residual ripple	---		12 < U <sub>B</sub> ≤ 30 VDC ≤ 0,1 % v. EW/10 V ≤ 10 % ss						
Output signal	---		4 ... 20 mA, 2-wire, passive, acc. to NAMUR NE 43 4 ... 20 mA, acc. to ATEX Ex II 2G Ex ia IIC T4 / T5 / T6 or. Ex I M2 Ex ia I 0 ... 20 mA, 3-wire; 0 ... 10 V, 3-wire						
Permissible max. load R <sub>A</sub>	---		R <sub>A</sub> ≤ (U <sub>B</sub> - 12 V)/0,02 A with R <sub>A</sub> in Ohm and U <sub>B</sub> in Volt, however max.600Ω						
Effect of load	---		≤ 0.1 % FS						
Electrical zero point	---		through a jumper across terminals 5 and 6 (see operating instructions)						
- Long-term stability of electronics	---		< 0.3 % of FS / a						
- Electrical output signal	---		≤ 1 % of measuring span						
Linearity	---		≤ 1.0 % of span (limit point calibration)						
Conformity specifications - Power supply - Short circuit rating - Rating - Internal capacitance - Internal inductance	---		Ex-Variant 14 ... 30 VDC I <sub>max.</sub> ≤ 100 mA U <sub>max.</sub> ≤ 1000 mW C <sub>i</sub> ≤ 12 nF mH negligible						
EMV-directive	---		2004/108/EG Interference emission (Limit class B) and immunity to EN 61 326-1						

1) Other electrical outputs and contacts on request

2) Similar to DIN 43 651

## Hand movement in a clockwise: open or close :

- Code <b>before</b> the point of contact function	- Digit <b>after</b> the dot indicates switching operation
1.--- : Magnetic snap action	---.1 : close
	---.2 : open
3.--- : Inductive contact	---.3 : simultaneously open and close (changer)
- <b>Number</b> of codes <b>after</b> the dot indicates the number of contacts	

# Dimensions

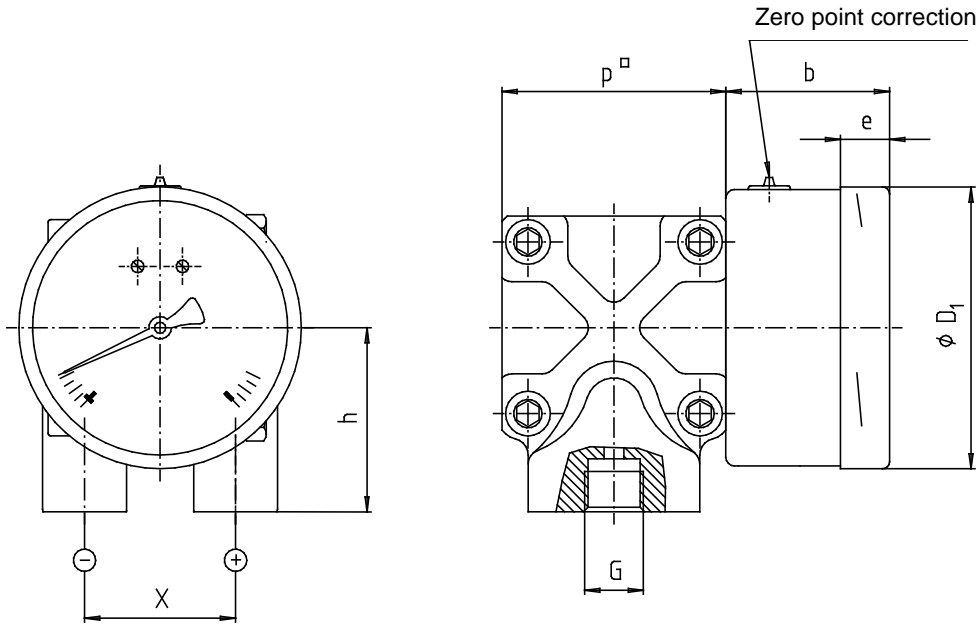

Model	ranges [ bar ]	dimension in mm								Weight [ kg ]
		ND	b	ø D <sub>1</sub>	e	G	h ± 1	p	X	
P2680/P2681	≤ 0.25	100	58.5 <sup>1)</sup>	101	17.5	G1/2	86	140	54	12.1
P2683/P2684	≥ 0.4		58.5 <sup>2)</sup>	101	17.5	G1/2	64	82	54	3.6
P2690/P2691	≤ 0.25	160	65.5 <sup>1)</sup>	161	17.5	G1/2	86	140	54	12.5
P2693/P2694	≥ 0.4		65.5 <sup>2)</sup>	161	17.5	G1/2	64	82	54	4.0

- 1) Model P2681 , P2683 with an electrical alarm contact: add 39 mm connection acc. to EN 837  
 2) Model P2691 , P2693 with an electrical alarm contact: add 36 mm  
 Model P2684 , P2694 with electrical output : add 50 mm

## Option

### Surface mounting bracket for wall or pipe mounting

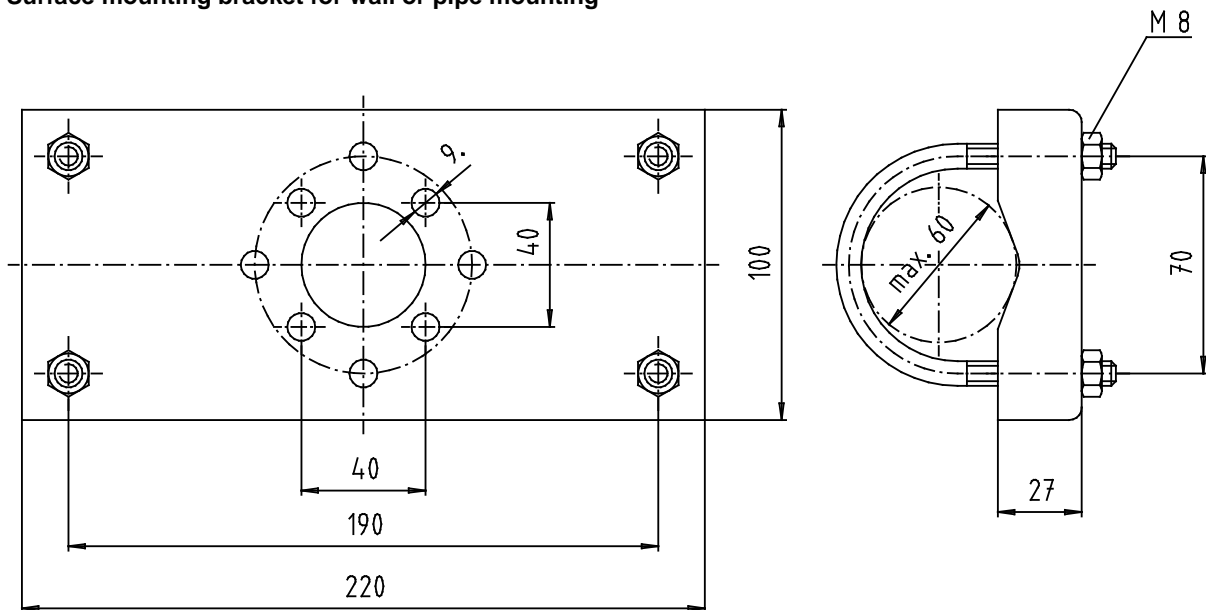

## Terminal assignment

Terminals 1 and 2 are the terminals for the signal output and for the power supply. The terminal marked with PE (protective earth) is connected internally to the housing. The connections 3 to 6 or 4 to 6 (for the 3-wire version), must remain free and must not be used as connection points (also see Chapter 10 "Technical data").

### 2-wire-design

i.E. 4 ... 20 mA

### 3-wire-design

i.E. 0 ... 20 mA / 0 ... 10 V

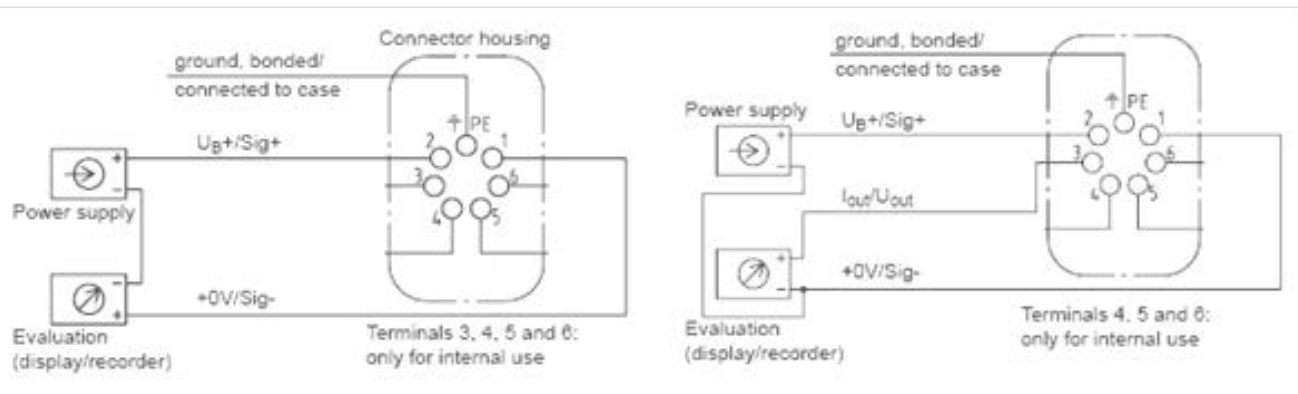

An un stabilised DC voltage, with a residual ripple of max. 10 % peak-to-peak in the range of the indicated supply voltage limits, is sufficient as a power supply. Make sure that the supply voltage applied exceeds the maximum required voltage by at least the value of the voltage drop across the external display or evaluation devices; i.e. the transmitter can operate using a non-stabilised supply voltage within the given limits, so long as the voltage available to the transmitter does not fall below 12 V, or below 14 V for the Ex-version.