



Profibus PA / Foundation Fieldbus transmitter

5350B

- PROFIBUS PA ver. 3.0
- FOUNDATION Fieldbus ver. ITK 4.6
- Automatic switch between protocols
- FISCO-certified
- Basic or LAS capability with F.F.



Application

- Linearized temperature measurement with RTD or TC sensor.
- Difference, average or redundancy temperature measurement with RTD or TC sensor.
- Linear resistance, potentiometer and bipolar mV measurement.

Technical characteristics

- Bus transmitter with both PROFIBUS PA and FOUNDATION Fieldbus communication. A unique switch function ensures automatic shift between the two protocols.
- Set-up for PROFIBUS PA can be done via Siemens Simatic® PDM®, ABB Melody / Harmony and Metso DNA software and for FOUNDATION Fieldbus via Emerson DeltaV, Yokogawa CS 1000 / CS 3000, ABB Melody / Harmony and Honeywell Experion software.
- The simulation mode function can be activated by way of a magnet.
- Polarity-independent bus connection.
- 24 bit A/D converter ensures high resolution.
- PROFIBUS PA function blocks: 2 analog.
- FOUNDATION Fieldbus function blocks: 2 analog and 1 PID.
- FOUNDATION Fieldbus capability: Basic or LAS.

Mounting / installation

- For DIN form B sensor head mounting.

Applications

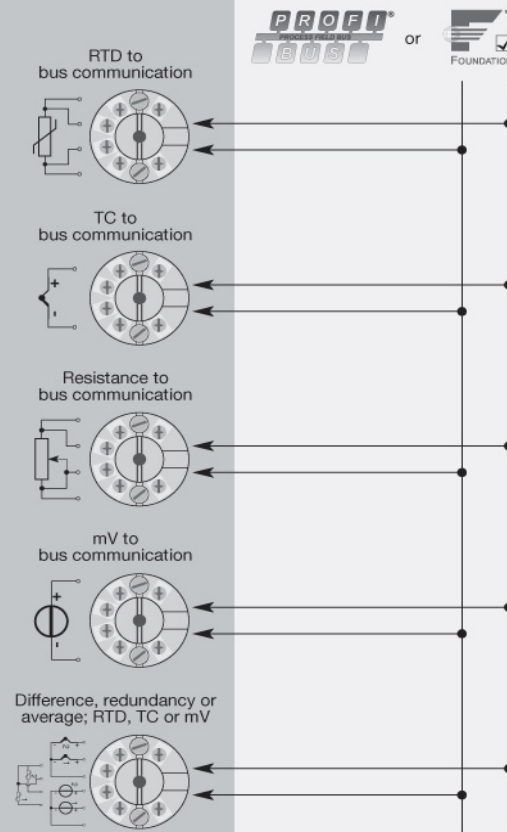

Order:

Type
5350B

Environmental Conditions

Operating temperature.....	-40°C to +85°C
Calibration temperature.....	20...28°C
Relative humidity.....	< 95% RH (non-cond.)
Protection degree (encl./terminal).....	IP68 / IP00

Mechanical specifications

Dimensions.....	Ø 44 x 20.2 mm
Weight approx.....	55 g
Screw terminal torque.....	0.4 Nm
Vibration.....	DIN class B, IEC 60068-2-6 and IEC 60068-2-64
2...25 Hz.....	±1.6 mm
25...100 Hz.....	±4 g

Common specifications**Supply**

Supply voltage.....	9.0...30 VDC
Supply voltage in FISCO installations.....	9.0...17.5 VDC
Max. required power.....	< 350 mW

Isolation voltage

Test voltage.....	1.5 kVAC for 60 s
Working voltage.....	50 VRMS / 75 VDC

Response time

Response time (programmable).....	1...60 s
Quiescent current.....	< 11 mA
Max. current increase in the event of an error.....	< 7 mA
Warm-up time.....	30 s
Signal / noise ratio.....	Min. 60 dB
Updating time.....	< 400 ms
Execution time, analog input.....	< 50 ms
Accuracy.....	Better than 0.05% of selected range
Signal dynamics, input.....	24 bit
EMC immunity influence.....	< ±0.1% of reading
Extended EMC immunity: NAMUR NE21, A criterion, burst.....	< ±1% of reading

Input specifications**RTD input**

RTD type.....	Pt25...1000, Ni25...1000, Cu10...1000, lin. R, potentiometer
Cable resistance per wire.....	50 Ω (max.)
Sensor current.....	Nom. 0.2 mA
Effect of sensor cable resistance (3-/4-wire).....	< 0.002 Ω / Ω
Sensor error detection.....	Yes
Short circuit detection.....	< 15 Ω

TC input

Thermocouple type.....	B, E, J, K, L, N, R, S, T, U, W3, W5
Cold junction compensation (CJC).....	< ±0.5°C
Sensor error detection.....	Yes
Sensor error current: When detecting / else.....	Nom. 4 µA / 0 µA
Short circuit detection.....	< 3 mV

Voltage input

Measurement range.....	-800...+800 mV
------------------------	----------------

Input resistance.....	10 MΩ
-----------------------	-------

Output specifications**PROFIBUS PA connection**

PROFIBUS PA protocol.....	Profile A&B, ver. 3.0
PROFIBUS PA protocol standard.....	EN 50170 vol. 2
PROFIBUS PA address (at delivery).....	126
PROFIBUS PA function blocks.....	2 analog

FOUNDATION Fieldbus connection

FOUNDATION Fieldbus protocol.....	FF protocol
FOUNDATION Fieldbus protocol standard.....	FF design specifications
FOUNDATION Fieldbus version.....	ITK 4.6
FOUNDATION Fieldbus capability.....	Basic or LAS
FOUNDATION Fieldbus function blocks.....	2 analog and 1 PID

Observed authority requirements

EMC.....	2014/30/EU
RoHS.....	2011/65/EU
EAC.....	TR-CU 020/2011

Approvals

ATEX.....	KEMA 02ATEX1318 X
IECEX.....	BVS 12.0035X
FM.....	3015609
CSA.....	1418937
INMETRO.....	DEKRA 18.0006 X
NEPSI.....	GYJ14.1101X
EAC Ex.....	RU C-DK.HA65.B.00355/19