

Cast-in heaters are an essential product for heating air, fluids and other components. Formed tubular heaters or heating coil are casted into aluminum or bronze to create the cast in heaters. Due to their special construction, cast-in heaters are contamination-resistant and corrosion-resistant. Air/liquid cooling systems are utilized for the cooling of cast in heaters. The cooling capabilities offer an efficient method of high accuracy temperature control. The heaters can be casted into any shape and size to customer specifications. The special construction and its features make this kind of heaters suitable for harsh environments with years of trouble-free service. These heaters have the advantage of the high thermal conductivity

of the aluminium that allows a quick heat transfer at the same time that allows a good thermal uniformity in the distribution of temperature. Therefore, that reduces the surface charge and increases the longevity of the heater. Cast-in heater uses a special aluminium alloy with a high fluidity, avoiding the formation of air pockets and a finishing without roughness. In addition, other materials can be used, for instance: bronze that guarantees a higher temperature and offers a greater resistance to contaminants.

## Application

Cast-in heaters offer optimum heat transfer directly to the contact surface. Cast-in heaters are strong and robust and are best used in processes requiring higher heat with greater reliability and longer life than other types of heating element. Transfer pipes, extrusion / injection moulding barrels and extrusion die blocks are commonly fitted with cast-in heaters.

- Plastic extrusion machine
- Textile industry
- Hot runner system
- Semiconductor processing
- Packaging
- Commercial pre-heater
- Extruder barrel
- Extrusion Die Heads
- Blow Moulding machines
- Glue pots
- Rubber presses
- Window machines
- Transfer machines
- Beverage Equipment
- Blown Film Discs
- Bun toasters
- Die and Nozzle Heater
- Food Warming Equipment
- Frying Equipment
- Laminating Equipment
- Liquid Heat Exchangers
- Packaging Seal Bars
- Platen Heaters
- Silicon Wafer Processing Equipment
- Silk Screen Equipment
- Vacuum Forming Equipment
- Wave Solder Equipment

**Cast In**

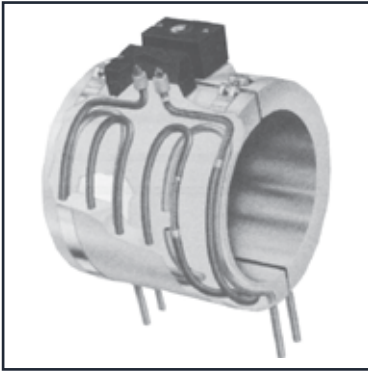

The cast-in heater is manufactured with a sheathed heater as its heat source. aluminium, cast iron, brass, etc. Selected according to use and working temperature, are cast under special techniques, and processed to achieve firm contact in accordance with the style of the heating section. This is a high performance heater with effective and uniform heating capacity. The MALTEC cast-in heater is a unique heater with high heat resistance, moisture resistance, corrosion resistance and durability, the cast-in heater can be cast into many forms, e.g., cylindrical, semicircular, conical, angular and plate. It is widely used for industrial purposes, including heater of kitchen cooking plate, synthetic resin extruder or molding and processing equipment. It has gained wide popularity in various field and is developing a still wider market.

**Construction**

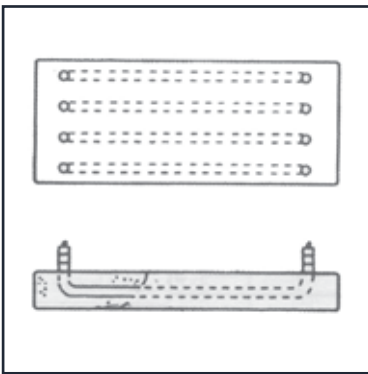

- Suitable for location where vibration and impact are present because it is strong against mechanical impact.
- Mounting on various equipment is simple
- As the heater is mounted in close contact with heater material according to style of the heater element, its heat conductivity and thermal efficiency are high.
- Thermal capacity is large and effective temperature control is possible. Power consumption is low because of high thermal efficiency.
- Casting material can be selected according to use and working temperature.
- Heat distribution in surface heating is even and easy, and working temperature.
- Highly moisture and durable.
- Thermal efficiency surface is high because it can be processed for accurate surface contact with the heated material.

**Cylindrical Type**

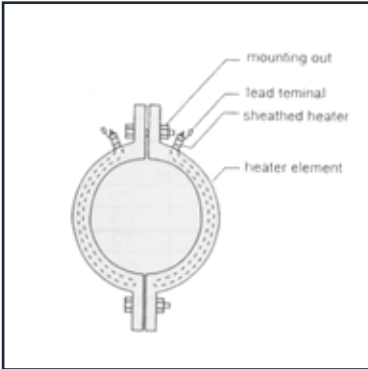

**Application**

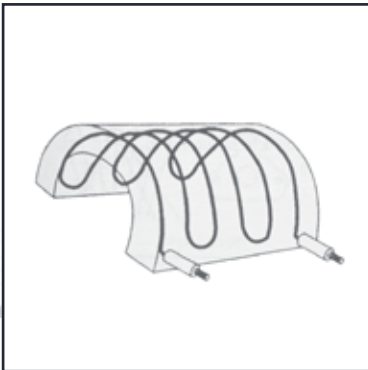

- As Nozzle and cylinder heater for synthetic resin extruder or molding and processing devices.
- Heating of thermal panels for molding and processing of synthetic resin, rubber, etc.
- For dissolving low-temperature processing alloys and plating solutions, etc.
- For heating laminating rolls and other heating rolls.
- For heat processing industrial and chemical products.
- For heating grills in cooking and baking
- Additional wide-scope heating applications.