

HE30HB / HE40HB

Blind shaft encoder

- Various output specification
- Simple installation method
- Wide range of power supply voltage (5 – 12 / 12 – 24 / 5 V DC)



Suffix code

Model		Code					Description
HE	<input type="checkbox"/> -	<input type="checkbox"/>	<input type="checkbox"/>	<input type="checkbox"/>	<input type="checkbox"/>	<input type="checkbox"/>	Closed shaft rotary encoder (Incremental)
Dimension	30HB	2					Outer diameter : Ø 30 mm, Inner diameter : Ø2 mm
		2.5					Outer diameter : Ø 30 mm, Inner diameter : Ø2,5 mm
		3					Outer diameter : Ø 30 mm, Inner diameter : Ø3 mm
	40HB	6					Outer diameter : Ø 40 mm, Inner diameter : Ø6 mm
		8					Outer diameter : Ø 40 mm, Inner diameter : Ø8 mm
		10					Outer diameter : Ø 40 mm, Inner diameter : Ø10 mm
		12				Outer diameter : Ø 40 mm, Inner diameter : Ø12 mm	
Number of pulse		*					Refer to the pulse code chart (resolving power)
Output signal (Output phase)			2				A, B phase output
			3				A, B, Z phase output
			3C				A, B, \bar{Z} phase output
			4				A, \bar{A} , B, \bar{B} phase output
			6				A, \bar{A} , B, \bar{B} , Z, \bar{Z} phase output
Output circuit		N	24				NPN Voltage output (12 – 24 V DC)
			12				NPN Voltage output (5 – 12 V DC)
		O	24				NPN Open collector output (12 – 24 V DC)
			12				NPN Open collector output (5 – 12 V DC)
		T	24				Totempole output (12 – 24 V DC)
			12				Totempole output (5 – 12 V DC)
		L	5				Line Driver output (5 V DC)
			12				Line Driver output (12 V DC) – Only for HE40HB
		24				Line Driver output (24 V DC) – Only for HE40HB	



Pulse code chart (Resolving power)

Model classification	Number of pulse per 1 revolution
HE30HB	100, 200, 360, 500, 1000, 1024
HE40HB	*1, *2, *5, 10, *12, 15, 20, 25, 30, 40, 45, 50, 60, 75, 100, 120, 125, 150, 192, 200, 240, 250, 256, 300, 360, 400, 500, 512, 600, 800, 1000, 1024, 1200, 1500, 1800, 2000, 2048, 2500

A and B phase only can be generated with 「*」mark (Line drive output : A, \bar{A} , B, \bar{B} phase)
Pulses other than pulses in the chart are order made product

Specification

Electrical specification

Phase difference on output	Phase difference between the phase A and B : $T/4 \pm T/8$ (1 cycle of A phase = T)	
Response speed	200 KHz max.	
Rated voltage	Voltage output	※ By the suffix code
	Open collector	5 – 12 V DC $\pm 5\%$
	Totem pole output	12 – 24 V DC $\pm 5\%$
	Line drive	HE30HB
HE40HB		5 / 12 / 24 V DC $\pm 5\%$
Current consumption	60 mA max (No load), Line drive output less than 30 mA (No load)	
Connection type	Cable extended type	
Control output	NPN voltage output	Load voltage : 30 V max, Load current : 30 mA max
	NPN open collector	Remaining voltage : 0.4 V max
	Totem pole	LOW (Load current : 30 mA max, Remaining voltage : 0.4 V max) HIGH (Load current : 10 mA max, Remaining voltage : Rated voltage above -2.5 V DC)
	Line driver	LOW (Load current : 20 mA max, 0.4 V max) HIGH (Load current : 20 mA max, Remaining voltage : 2.5V)
Response time	Voltage output	1 μ s max (Wire length : 1.5 m, Sinking current = 30 mA)
	Open collector	
	Totem pole	1 μ s max (Wire length : 1.5 m, Sinking current = 10 mA max.)
	Line drive	1 μ s max (Wire length : 1.5 m, Sinking current = 30 mA max.)

Environmental specification

Model	HE30HB (Ø30)	HE40HB (Ø40)
Insulation resistance	100 M Ω min (Between the terminal and case 500 V DC mega standard)	
Dielectric strength	800 V AC (For 1 min in 60 Hz between the terminal and case)	
Vibration resistance	10 – 55 Hz (Period for 1 min), Double amplitude : 1.5 mm, for 2 hour each in X, Y and Z directions	
Shock resistance	490 g max.	735 g max.
Ambient temperature	-10 ~ 70 °C (No icing allowed), When storing : -25 ~ 85 °C	
Ambient humidity	35 ~ 85 % RH	
Wire specification	5P, Ø 5.0 mm, Length : 1.5 m, Shield cable (Line drive type : 8P, Ø 5.0 mm, Length : 1.5 m, Shield cable)	
Accessory	Bracket	
Weight	Approx. 120 g	Approx. 170 g

Mechanical specification

Model	HE30HB (Ø30)	HE40HB (Ø40)
Starting torque	$2 \times 10^{-3} \text{ N} \cdot \text{m}$ max	$4 \times 10^{-3} \text{ N} \cdot \text{m}$ max
Moment of inertia	$2 \times 10^{-6} \text{ kg} \cdot \text{m}^2$ max	$4 \times 10^{-6} \text{ kg} \cdot \text{m}^2$ max
Permissible shaft loading	Radial : 15 N within, Thrust : 10 N within	Radial : 30 N within, Thrust : 20 N within
Max permissible revolution	5000 r/min	

Input/output circuit

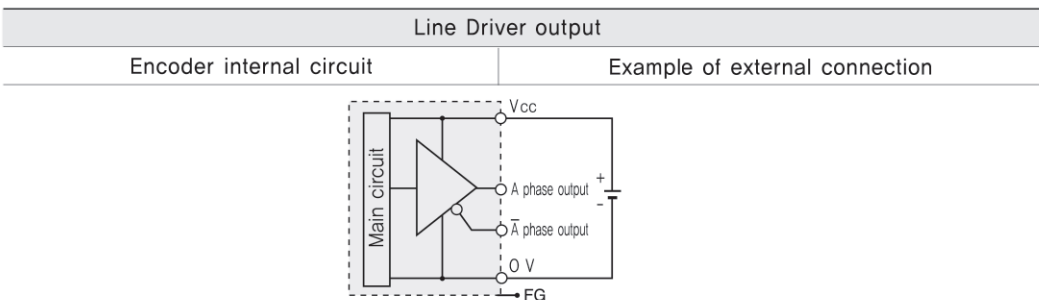
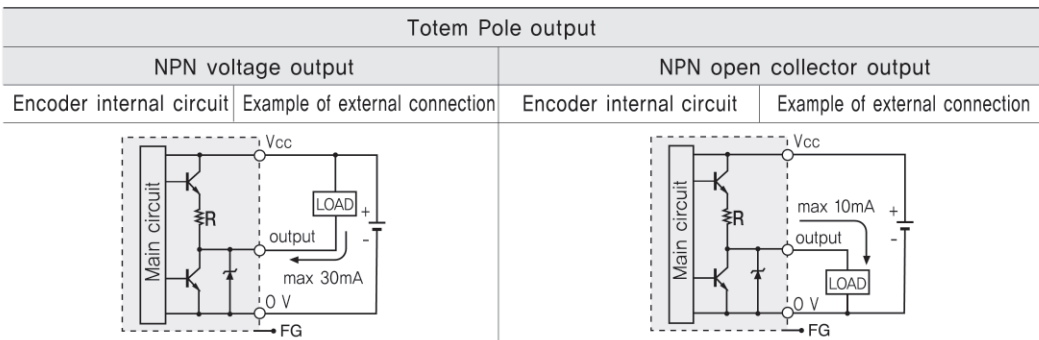
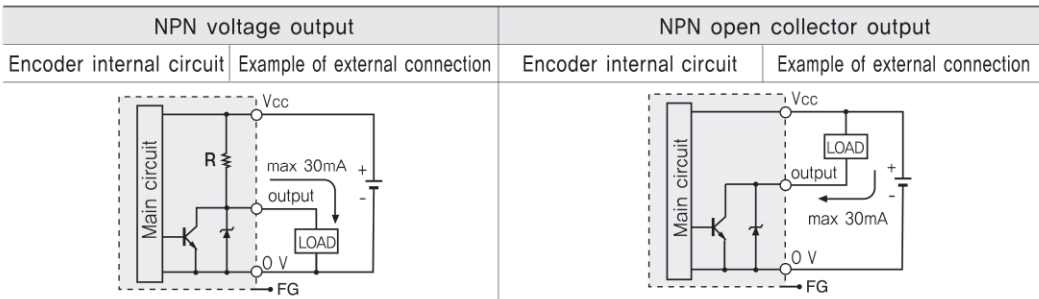

※ For the output circuit, phases A, B and Z are same(Line drive output is A, \bar{A} , B, \bar{B} , Z, \bar{Z})



Output wave form

■ NPN voltage output, NPN open collector output, Totem pole output

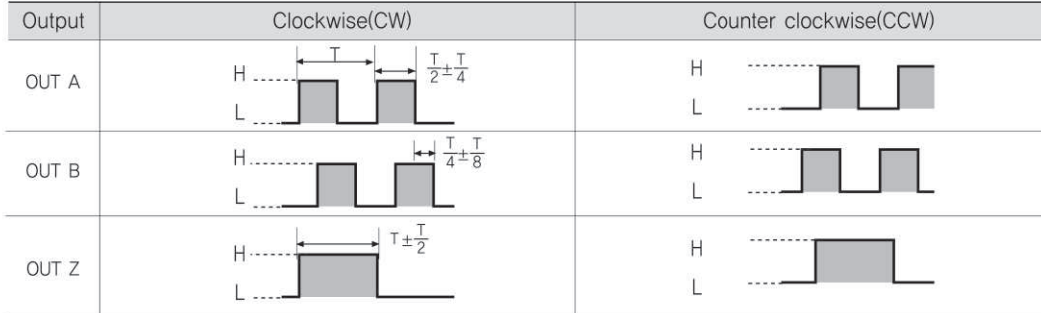

■ Line driver output

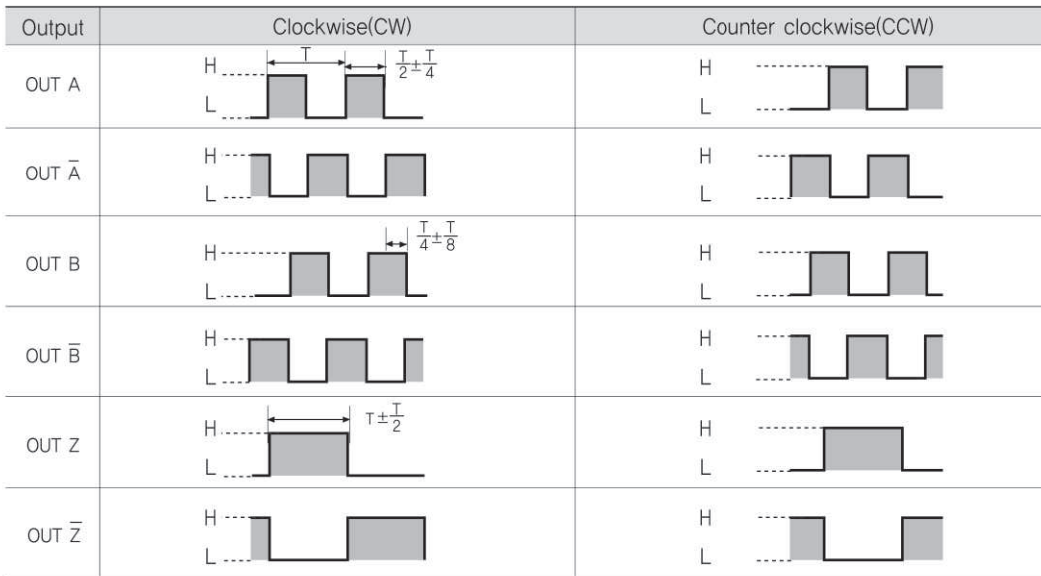

* Clockwise (CW) : Turning to the clockwise direction when looking at from the shaft of the product.

* Counter clockwise (CCW) : Turning to the counter clockwise direction when looking at from the shaft of the product.

Dimension (Unit : mm)

HE30HB (Ø30)

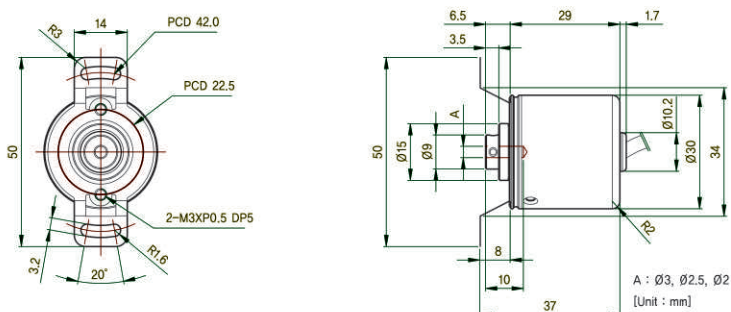

HE40HB (Ø40)

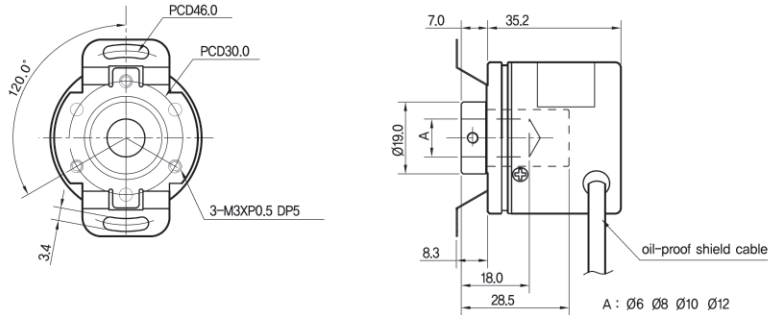

Connection diagram

Ø30 Blind shaft

■ Voltage output, Totem pole output, open collector output ■ Line driver output

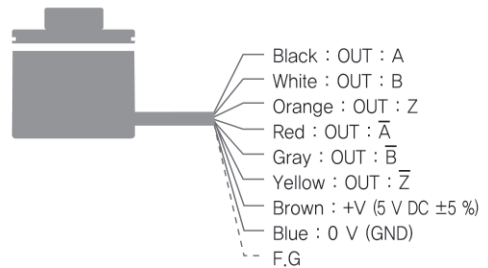
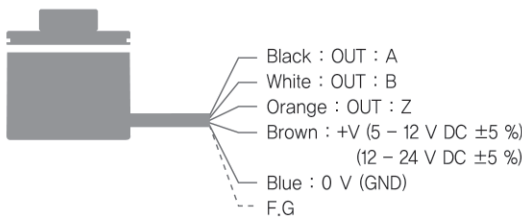

Ø40 Blind shaft

■ Voltage output, Totem pole output, open collector output ■ Line driver output

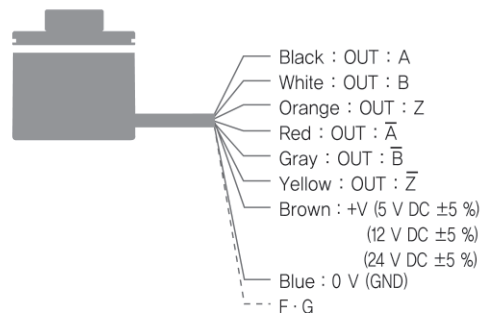
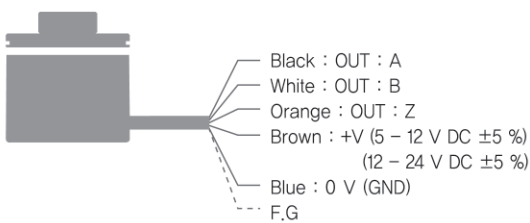

※ Please insulate the wires that are not used

※ Metal case of encoder and shield line must be earthed (F.G)