



## Industrial Process Pressure Gauge

S/S Casing according to EN 837-1/S2

- ✓ Nominal sizes ND 63, ND 100, ND 150
- ✓ Case: SS304
- ✓ Ring: SS304 (detachable)
- ✓ Window: plexiglass (standard); safety glass (optional)
- ✓ Internals: brass (standard)
- ✓ Socket: brass (standard)
- ✓ Ranges: -1 - 0 Bar/Psi to 0 - 700 Bar/Psi

### Description

The time proven system technology of the glycerine pressure gauges has been integrated in a new stainless steel case with modern design. The glycerine filling of the case protects the measuring system against wear by pulsating pressures and mechanical vibration; at the same time it provides lubrication of the moving parts. The glycerine pressure gauges are suitable for gaseous and liquid media that do not corrode copper alloys. The pressure gauges are equipped with a pressure compensating diaphragm. This diaphragm avoids a pressure rise in the case that is due to temperature bound volume expansion of the liquid filling, thus avoiding indicated errors.

### Features

- High dynamic load
- Rugged construction
- Low wear
- Versatile applications
- Reducing of stocking costs
- Low weight

### Application

- Food Industry
- Chemical Industry
- Shipyards
- Water Treatment
- Waste Water
- Power Plant
- Hydraulics
- Pumps
- Compressors, High Pressure Cleaning Devices.

## Technical Data

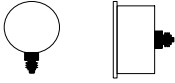
Model	VPG	Options
Nominal Size	63 / 100 / 150	-
Symbol		-
Accuracy class	2.5" is 1.6%, 4" is 1%	-
Ranges	0...1 bar to 0...1000 bar negative or positive or negative and positive gauge pressure	-
Application	Constant load: 3/4 x full scale value Alternating load: 2/3 x full scale value	-
Overpressure protection	full scale value	-
Case	Stainless steel 1.4301 bright	Polished
Bezel	Stainless steel 1.4301 bright	-
Mounting	None	Front flange, stainless steel polished, triangular bezel, polished stainless steel
Window	Plexiglass	Trogamid T
Dial	Aluminium, white, scale and imprint black	Dual scale
Pointer	Aluminium, black	red max.pointer
Movement	CuZn-alloy	-
Measuring element	Copper alloy up to 40 bar Bourdon tube; above 60 Bar: helical tube; stainless steel 1.4571 ≥ 400 bar helical tube	-
Thread - position - thread	CuZn-alloy above 1/4" BSP/NPT ; 1/2" BSP/NPT	back, central Other threads on request
Liquid filling	Glycerine < 2.5 bar 86.5%, ≥ 2.5 bar 99.5%	-
Temperature - Medium - Ambient	Tmin. -25°C, Tmax. 80°C Tmin. -25°C, Tmax. 60°C	-
Temperature drift	0.3%/10K if deviation from normal temperature 20°C	-
Protection	IP 65 to EN 60 529/IEC 529	-
Orifice	-	Ø 0.3 ; Ø 0.4 ; Ø 0.8 Brass
Weight approx.	0.21 kg	-

## Part Numbering System

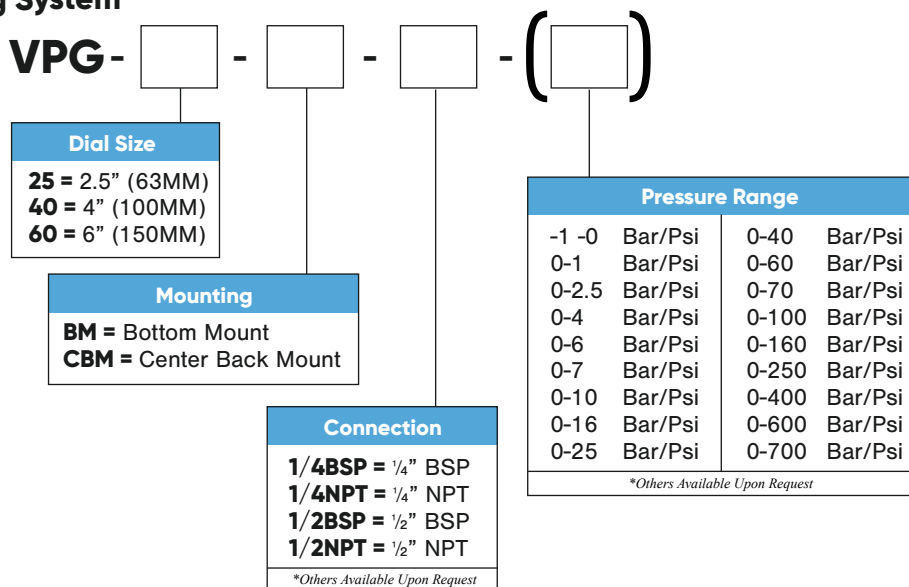

**Example: VPG** - 25 - BM - 1/4NPT - (0-100Bar/Psi)