

°C
%RH
SHIMADEN

Series **FP93**

SHIMADEN PROGRAM CONTROLLER



BASIC FEATURES

- Full multi-input and multi-range performance**
User selectable Thermocouple, RTD, V, mV and Current inputs
A 250 Ω resistor is required across the input terminal for 4-20mA DC.
- Large 20mm bright display**
- Readable from a distance and in a low light area**
- 40-step programs function**
- RS232C or RS485 Interface available**
- Dust and splash proof front panel equivalent to IP66**

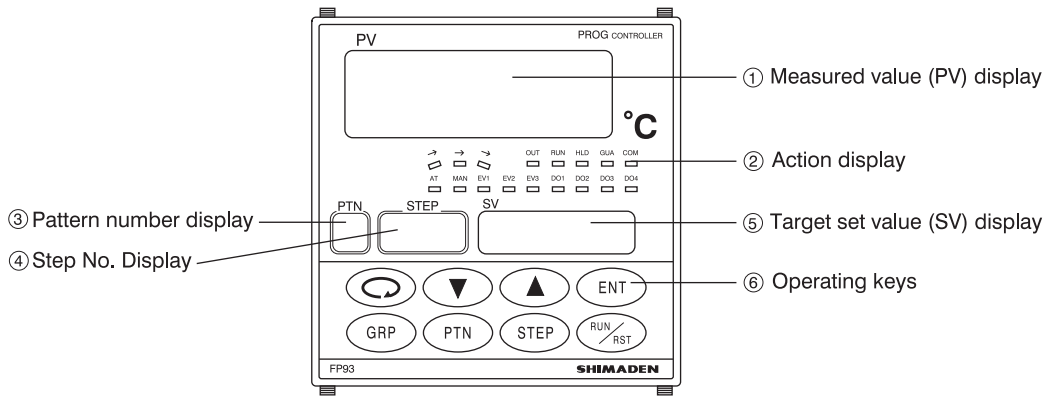

Series FP93
96 (H) × 96 (W) × 111 (D) mm

◆ Major Functions

■ Zone PID

Controllability is improved by changing PID values automatically as a program progresses. A measuring range can be divided into a maximum of three zones.

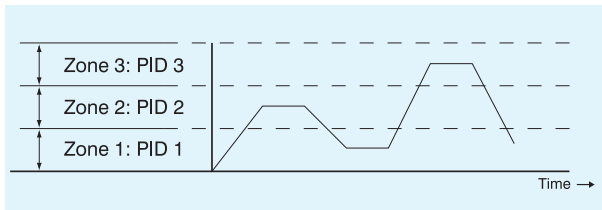

■ Guarantee soak function

If a PV value is unable to follow an SV value, the period of a flat portion step is guaranteed by keeping the progress of a program on standby.

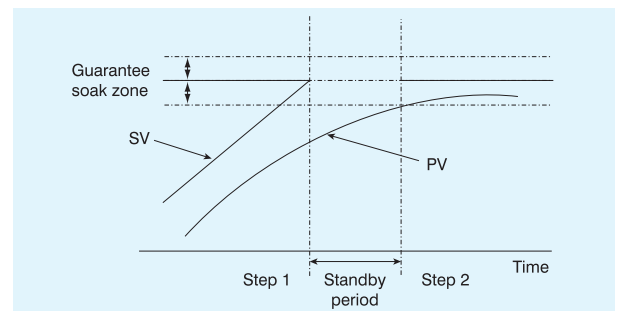

■ PV start

In situations where a PV value is closer to the SV value of step 1 than a start SV value, you can minimize the time wasted.

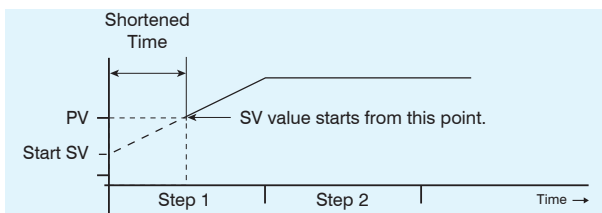

■ External control input 4 points

The following can be operated through external contact input:

Function	Action
RUN / RST	Switching between program execution and stop
ADV	Bringing the current step to an end and moving to the next step
HLD	Temporarily suspending the progress of the program
FIX	Changing to the fixed value control mode
SPT	Setting a pattern No. at the start of program action

- Event output 3 points (standard)
Status output 4 points (option)
Contact for event output and Open collector for status output can be selected and output from a variety of functions listed below.

Output type	Event output	Status output
None	○	○
Higher limit deviation alarm	○	
Lower limit deviation alarm	○	
Outside higher/lower limit deviations alarm	○	
Within higher/lower limit deviations alarm	○	
Higher limit absolute value alarm	○	
Lower limit absolute value alarm	○	
Scaleover	○	○
Hold	○	○
Guarantee soak	○	○
Time signal	○	○
RUN status	○	○
Step signal	○	○
End signal	○	○
FIX	○	○

- Time signal 2 points (for each pattern)
Designated time can be made use of, for example, to open/close a damper and a valve through event or status output.

- Analog output (option)
The PV value, SV value and/or the control output can be output by means of an analog signal.

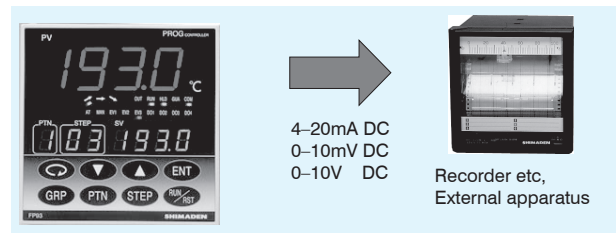

- Communication function (option)
Data communication to/from a personal computer, sequencer or the like can be performed by means of RS-232C or RS-485 signals.

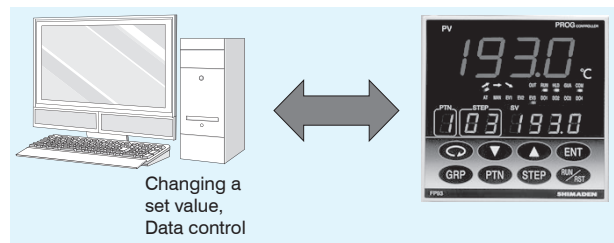

◆ An application example



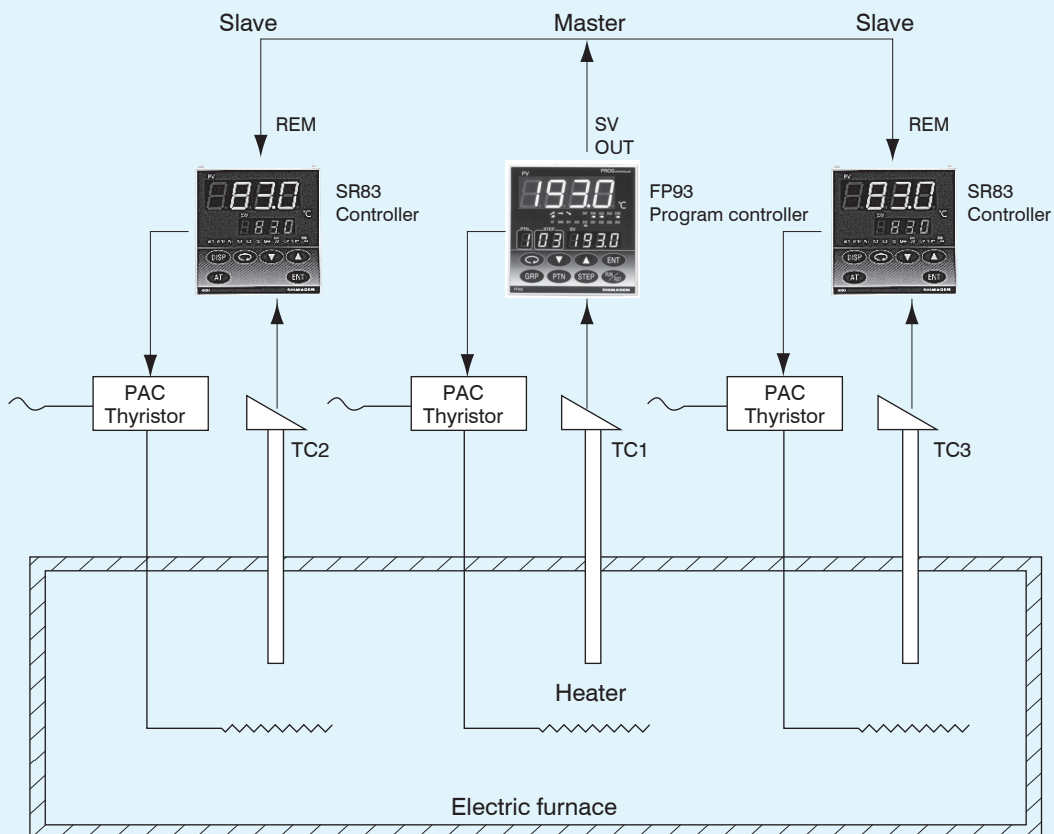



Temperature control for a tunnel furnace program



■ **Display**

- Display means
 - Digital display : PV Red 7 segments LED 4 digits
 - : SV Green 7 segments LED 4 digits
 - : PTN Green 7 segments LED 1 digit
 - : STEP Green 7 segments LED 2 digits
 - Status display : OUT Green LED lamp indication
 - : EV1-3 (3 points) Orange LED lamp indication
 - : AT Green LED lamp indication
 - : MAN Green LED lamp indication
 - : COM Green LED lamp indication
 - : DO1-4 (4 points) Green LED lamp indication
 - : GUA Green LED lamp indication
 - : RUN Green LED lamp indication (blinks during FIX)
 - : HLD Green LED lamp indication
 - : ↗ "ascend" Green LED lamp indication
 - : → "level" Green LED lamp indication
 - : ↘ "descend" Green LED lamp indication
- Display accuracy : $\pm(0.3\%FS + 1 \text{ digit})$, with restriction depending on measuring range, CJ error excluded.
- Display accuracy maintaining range : $23 \text{ }^\circ\text{C} \pm 5 \text{ }^\circ\text{C}$
- Display resolution : Differs by scaling and measuring range (0.001, 0.01, 0.1 and 1)
- Measured value display range : -10%~110% of measuring range
(-210~680 $^\circ\text{C}$ for Pt -200~600 $^\circ\text{C}$ range)
- Display updating cycle : 0.25 second
- Input scaling : Possible during linear input (current and voltage)
(-1999~9999, span 10~5000, decimal point position variable)

■ **Setting**

- Local Setting : Operated by 8 keys (, , , , , , ) on the front panel
- SV setting range : Same as measuring range (within setting limiter)
- Setting limiter : Individual setting for higher and lower limits, any value is selectable within measuring range
(Lower limit < Higher limit)
- Keylock : OFF, 1-3 (4 levels)
- Setting of unit : $^\circ\text{C}$ or $^\circ\text{F}$ selectable for sensor input

■ **Input**

- Type of input : Selectable from multiple (TC, Pt, mV, V) and current (mA)
 - Thermocouple : B, R, S, K, E, J, T, N, PLII, Wre5-26, {U, L (DIN43710)}
 - Input impedance : 500 k Ω min.
 - External resistance tolerance : 100 Ω max.
 - Influence of lead wire tolerance : 1.2 $\mu\text{V}/10 \text{ } \Omega$
 - Burnout function : Standard up scale
 - Cold junction compensation accuracy : Within the accuracy maintaining range $\pm 1 \text{ }^\circ\text{C}$
Ambient temperature 5~45 $^\circ\text{C} \pm 2 \text{ }^\circ\text{C}$
For K, T and U thermocouples with indication values below -100 $^\circ\text{C}$, $\pm 0.7\% \text{ FS}$
Accuracy guarantee not applicable to B thermocouple below 400 $^\circ\text{C}$ (752 $^\circ\text{F}$).
 - R.T.D. : Pt100/JPt100 3-wire type
 - Normal current : 0.25 mA
 - Lead wire tolerable resistance : 5 Ω max./wire (3 lead wires should have the same resistance.)
Influence of lead wire tolerance (error in temperature)
0.3 $^\circ\text{C}$ max. in the case of 5 Ω /wire
0.7 $^\circ\text{C}$ max. in the case of 10 Ω /wire
1.6 $^\circ\text{C}$ max. in the case of 20 Ω /wire
 - Voltage (mV) : -10~-10, 0~-10, 0~-20, 0~-50, 10~-50, 0~-100mV DC
 - (V) : -1~-1, 0~-1, 0~-2, 0~-5, 1~-5, 0~-10V DC
 - Input resistance : 500 k Ω min.
 - Current (mA) : 4~-20, 0~-20mA DC
: To be used with external 250 Ω shunt resistor (Option)
 - Sampling cycle : 0.25 second
 - PV filter : 0~100 seconds
 - PV bias : -1999~2000 digits
 - Isolation : Not insulated from system and DI but insulated from others
- **Control**
- Control mode : Expert PID control with auto tuning function
RA (heating)/DA (cooling) action
 - Type of control output/rating : Contact 1c 240V AC 2.5A(resistive load) 1.0A (inductive load)
SSR drive voltage 12V \pm 1.5V DC (max. load current 30mA)
Current 4~20mA (max. load resistance 600 Ω)
Voltage 0~10V (max. load current 2mA)
 - Resolution : Approx. 1/8000 (voltage, current outputs)
 - Output Accuracy : $\pm 1.0\% \text{ FS}$ (5~100%)

- Control output
 - Proportional band (P) : OFF or 0.1–999.9% FS (ON-OFF action by OFF)
 - Integral time (I) : OFF or 1–6000 seconds (P or PD action by OFF)
 - Derivative time (D) : OFF or 1–3600 seconds (P or PI action by OFF)
 - Target value function : OFF or 0.01–1.00
 - ON/OFF hysteresis : 1–999 digits
 - Manual reset : $\pm 50.0\%$ (Effective when I = OFF)
 - Output limiter : Lower limit 0.0–99.9%, higher limit 0.1–100.0%
 - Proportional cycle : 1–120 seconds (when contact and SSR drive voltage output)
 - Manual control : 0.0–100.0% Setting resolution 0.1
- Control output characteristic : RA/DA to be set by front key
- Isolation : Contact output insulated from all
AO (analog output) not insulated from SSR drive voltage, current or voltage output but insulated from others

■ External control input (DI)

*DI stands for "Digital Input."

- Number of input points : 4
- Type of input : Edge or level input (none, RUN/RST, HLD, ADV, FIX and start pattern No.)
DI1 fixed to RUN/RST for DI2–DI4, selectable from none, HLD, ADV, FIX and start pattern No.)
- Input rating : Voltage 5V DC (0.5mA/1 input)
- Input holding time : Min. 0.125 seconds
- Isolation : Not insulated from input and system but insulated from others.
- Action input : Non-voltage contact or open collector
- **Event output**
 - Contact output rating : Normal open (1a \times 3 common) 240V AC 1A (resistive load)
 - Action : ON-OFF action
 - Hysteresis : 1–999 digits (during alarm output)
 - Type : Selectable from the following 16 types respectively for EV1, EV2 and EV3
No selection, Higher limit deviation, Lower limit deviation, Outside higher/lower limit deviations, Within higher/lower limit deviations, Higher limit absolute value, Lower limit absolute value, Scaleover, Hold, Guarantee soak, Time signal (2 types), RUN status, STEP signal, END signal, FIX
 - Event setting range:
 - Absolute value alarm : Within measuring range
 - Deviation alarm : Higher limit deviation -1999–2000 digits, lower limit deviation -1999–2000 digits
 - Outside higher/lower limit deviations : 0–2000 digits
 - Within higher/lower limit deviations : 0–2000 digits
 - Standby action : Selectable from the following 4 types respectively for EV1, EV2 and EV3
None, Standby 1 (standby only when power is applied), Standby 2 (standby when power is applied and when SV in execution is changed), and Standby 3 (input abnormality not output [Control mode])
 - Output updating cycle : 0.25 second
 - Isolation : Insulated from other inputs

■ Communication function (Option)

- Type of communication : RS-232C or RS-485
- Communication system : RS-232C/3-line type half duplex system, RS-485/2-line type half duplex multi-drop (bus) system
- Synchronization system : Start-stop synchronization system
- Communication distance : RS-232C/Max. 15m, RS-485/Max. 500 m (depending on conditions)
- Communication address : 1–255
- Communication speed : 1200, 2400, 4800, 9600, 19200 bps
- Communication delay : 1–100 (0.512msec/unit)
- Communication memory mode : Selectable from EEP, rAm and r_E
- Communication protocol : Shimaden standard mode
 - Data format : 7E1, 7E2, 7N1, 7N2, 8E1, 8E2, 8N1, 8N2
 - Control code : STX_ETX_CR, STX_ETX_CRLF, @, _ :_CR
 - Checksum (BCC) : Add, Add two's cmp, XOR, None
 - Communication code : ASCII data
 - : MODBUS ASCII mode
 - Data format : 7E1, 7E2, 7N1, 7N2
 - Control code : CRLF
 - Checksum (BCC) : LRC check
 - Communication code : ASCII data
 - Function code : 03H, 06H
 - 1)03H Reading of data
 - 2)06H Writing of data
 - : MODBUS RTU mode
 - Data format : 8E1, 8E2, 8N1, 8N2
 - Control code : NON
 - Checksum (BCC) : CRC-16
 - Communication code : Binary data
 - Function code : 03H, 06H
 - 1)03H Reading of data
 - 2)06H Writing of data

- Communication mode type : Selectable from COM1 and COM2.
 - Number of connectable instruments : 1 for RS-232C, 31 for RS-485 (Address setting 1–255)
 - Isolation : insulated from other inputs and outputs
 - Others : Start character and BCC operation method also selectable
- **Analog output (Option)**
- Number of output points : 1
 - Type of analog output : Selectable from measured value, target value (SV in execution) and control output
 - Output specification/rating : Current 4–20mA DC (max. load resistance 300 Ω)
Voltage 0–10V DC (max. load current 2mA)
0–10mV DC (Output resistance 10 Ω)
 - Output accuracy : ±0.3% FS (Comprehensive accuracy when measured value is output ±0.6% FS)
 - Scaling : Within measuring range or output range (inversed scaling possible)
 - Output resolution : Approx. 1/10000
 - Output updating cycle : 0.25 second
 - Isolation : Not insulated from P.I.V. control output but insulated from others
- **Status output (DO) (Option)**
*DO stands for "Digital Output."
- Number of output points : 4
 - Type of output : None, scaleover, hold, guarantee soak, time signal (2 types), RUN status, STEP signal, END signal, FIX
 - Output specification/rating : Open collector darlington output, voltage 24V DC (max. load current 20mA), saturation voltage during status output ON 1.2V
 - Output updating cycle : 0.25 second
 - Isolation : Insulated from other inputs and outputs
- **Program**
- Number of patterns : Max. 4 (setting 1, 2 or 4 possible)
 - Number of steps : Max. 10–40 (Total number of steps = 40)
 - Number of PID types : Max. 6
 - Number of zone PID types : Max. 3
 - Zone hysteresis : 0–999 digits
 - Time setting : 0 hour 0 minute–99 hours 59 minutes or 0 minute 0 second–99 minutes 59 seconds/1 step
 - Setting resolution : 1 minute or 1 second
 - Accuracy of time : ± (set time × 0.02% + 0.25 second)
 - Setting for each step : SV, step time and PID No.
 - Time signal : 2 outputs/pattern, to be set within time setting range
 - Number of pattern executions : Max. 9999
 - PV start : ON/OFF
 - Guarantee soak : OFF, 1–999 digits
 - Hold : By front key input or external control input
 - Advance : By front key input or external control input
 - Power failure compensation : ON/OFF (guarantee not applicable to the period of time of step in which power failure occurs)
- **General specification**
- Data storage : Non-volatile memory (EEPROM)
 - Ambient conditions for operation:
 - Temperature : -10–50 °C
 - Humidity : 90% RH or less (no dew condensation)
 - Altitude : 2000m from the sea level or lower
 - Category : II
 - Degree of pollution : 2
 - Storage temperature : -20–65 °C
 - Supply voltage : 100–240V AC±10% 50/60Hz
24V AC/DC±10% (option)
 - Input/noise removal ratio : 50 dB or higher in normal mode (50/60 Hz)
130 dB or higher in common mode (50/60 Hz)
 - Insulation resistance : Between input/output terminals and power terminal 500V DC 20 MΩ min.
Between input/output terminals and protective conductor terminal 500V DC 20 MΩ min.
 - Dielectric strength : Between input/output terminals and power terminal 3000V AC 1 minute
Between power terminal and protective conductor terminal 1500V AC 1 minute
 - Power consumption : 16VA max. for AC, 7W for DC
 - Conformity with standards
 - Safety : IEC61010-1 and EN61010-1
 - EMC : EN61326-1
 - RoHS : EN50581
 - Protective structure : Only front panel has dust-proof and drip-proof structure equivalent to IP66.
 - Material of case : PPO (equivalent to UL94V-1)
 - External dimensions : H96 × W96 × D111 mm (Panel depth: 100 mm)
 - Panel thickness : 1.0–4.0 mm
 - Mounting dimensions : H92 × W92 mm
 - Weight : Approx. 450g

ITEMS		CODE		SPECIFICATIONS	
SERIES	FP93-	96 x 96 DIN size Program controller (External control input 4 points, event output 3 points - standard)			
INPUT	8	Multi	Thermocouple	B, R, S, K, E, J, T, N, PLII, Wre5-26, U, L	
			R.T.D.	Pt100, JPt100	
			Voltage	mV: -10-10, 0-10, 0-20, 0-50, 10-50, 0-100mV DC	Scaling possible
	4	Current	4-20, 0-20mA DC (equipped with external 250 shunt resistor)	Range: -1999-9999	Span: 10-5000
CONTROL OUTPUT	Y-	Contact 1c Contact capacity: 240AC 2.5A/resistive load Proportional cycle: 1-120 seconds			
	I-	Current 4-20mA DC Load Resistance: 600 max.			
	P-	SSR drive voltage 12V ±1.5V DC 30mA max. Proportional cycle:1-120 seconds			
	V-	Voltage 0-10V DC Load current: 2mA max.			
POWER SUPPLY	90-	100-240V AC ±10% 50/60Hz			
	08-	24V AC/DC ±10% 50/60Hz			
STATUS OUTPUT (DO) (OPTION)	0	None			
	1	Open collector darlington output Rating: 24 V DC max. 20mA			
ANALOG OUTPUT (OPTION)	0	None			
	3	Voltage: 0-10mV DC Output resistance: 10			
	4	Current: 4-20mA DC Load resistance: 300 max.			
	6	Voltage: 0-10V DC Load current: 2mA max.			
COMMUNICATION FUNCTION (OPTION)	0	None			
	5	RS-485	Shimaden standard protocol/MODBUS communication protocol		
	7	RS-232C			
REMARKS	0	Without			
	9	With (Please consult before ordering.)			

MEASURING RANGE CODES

Type of input	Code	Scaling range		Type of input	Code	Scaling range			
Thermocouple	B *1	01	0 - 1800 °C	0 - 3300 °F	Voltage (mV)	-10 - 10	71		
	R	02	0 - 1700 °C	0 - 3100 °F		0 - 10	72	Optional setting of Measuring range is possible by the scaling function as shown below.	
	S	03	0 - 1700 °C	0 - 3100 °F		0 - 20	73		
	*3	04	-199.9 - 400.0 °C	-300 - 750 °F		0 - 50	74		
	K	05	0.0 - 800.0 °C	0 - 1500 °F		10 - 50	75		Scaling range: -1999-9999 digits Span: 10-5000 digits
		06	0 - 1200 °C	0 - 2200 °F		0 - 100	76		
	E	07	0 - 700 °C	0 - 1300 °F	Voltage (V)	-1 - 1	81		
	J	08	0 - 600 °C	0 - 1100 °F		0 - 1	82		
	T *3	09	-199.9 - 200.0 °C	-300 - 400 °F	0 - 2	83			
	N	10	0 - 1300 °C	0 - 2300 °F	0 - 5	84			
	PLII *4	11	0 - 1300 °C	0 - 2300 °F	1 - 5	85			
	Wre5-26 *5	12	0 - 2300 °C	0 - 4200 °F	0 - 10	86			
	U *2, *3	13	-199.9 - 200.0 °C	-300 - 400 °F	Current (mA)	0 - 20	91		
	L *2	14	0 - 600 °C	0 - 1100 °F		4 - 20	92		
R.T.D.	Pt100	31	-200 - 600 °C	-300 - 1100 °F	Note: *1 Thermocouple B: Accuracy guarantee not applicable temperature below 400 °C. *2 Thermocouple U, L: DIN 43710 *3 Thermocouple K, T, U: Accuracy guarantee not applicable temperature below -100 °C. ±(0.7%FS+1digit) *4 Thermocouple PLII: Platinel *5 Thermocouple Wre5-26: A product of Hoskins				
		32	-100.0 - 100.0 °C	-150.0 - 200.0 °F					
		33	-50.0 - 50.0 °C	-50.0 - 120.0 °F					
	JPt100	34	0.0 - 200.0 °C	0.0 - 400.0 °F					
		35	-200 - 500 °C	-300 - 1000 °F					
		36	-100.0 - 100.0 °C	-150.0 - 200.0 °F					
37	-50.0 - 50.0 °C	-50.0 - 120.0 °F							
38	0.0 - 200.0 °C	0.0 - 400.0 °F							

Note: Unless otherwise specified, the measuring range will be set as listed below during the shipment from the factory.

Input	Specification/ Rating	Measuring range
Multi input	K thermocouple	0.0-800.0 °C
Current (mA)	4-20mA DC	0.0-100.0

TERMINAL COVER (AVAILABLE SEPARATELY)

Model	Mounting
QCR003	One-touch mount

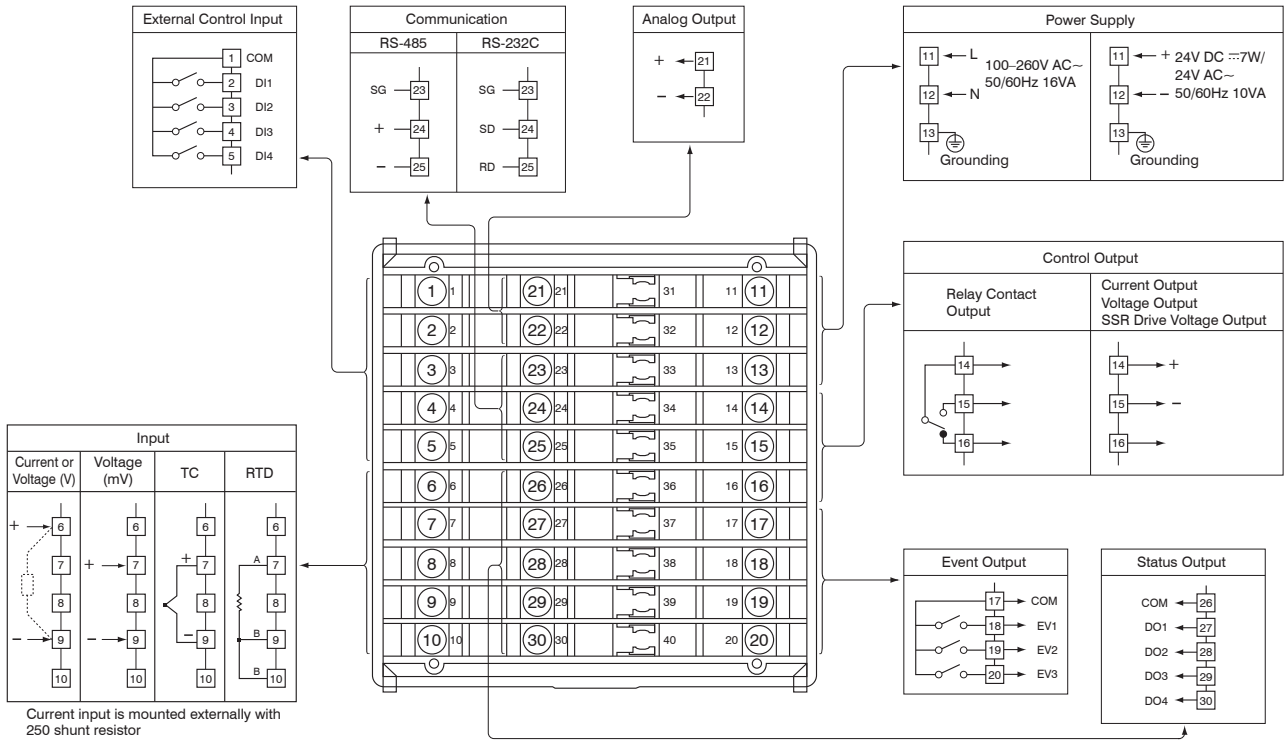

EXTERNAL DIMENSIONS & PANEL CUTOUT

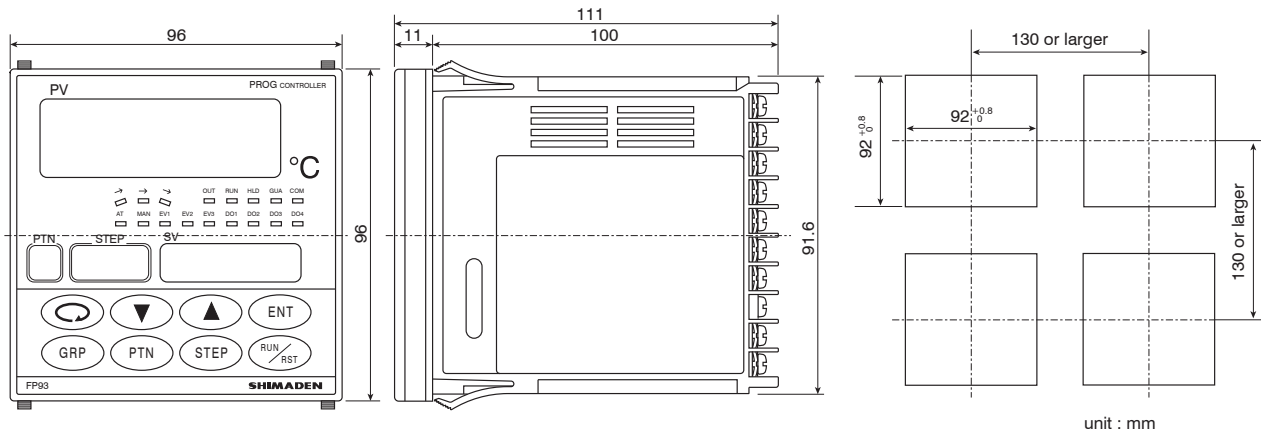

Warning

- The FP93 series is designed for the control of temperature, humidity and other physical values for the general industrial equipment. It is not to be used for any purpose which regulates the prevention of serious effects on human life or safety. No warranty, express or implied is valid if used without proper safety measures.

Caution

- If the possibility of loss or damage to your system or property as a result of failure of any part of the process exists, proper safety measures must be made before the instrument is put into use as to prevent the occurrence of trouble.

Head Office & Saitama Factory
ISO 9001/ISO 14001 Certification Obtained

(The contents of this brochure are subject to change without notice.)

Temperature and Humidity Control Specialists
SHIMADEN CO., LTD.

Head Office: 2-30-10 Kitamachi, Nerima-Ku, Tokyo 179-0081 Japan
Phone: +81-3-3931-7891 Fax: +81-3-3931-3089
E-MAIL: exp-dept@shimaden.co.jp URL: http://www.shimaden.co.jp